

3-Hour Fire Rating

8" C.M.U.

Fire Rating: 3 Hour

No. 8-3-910720SD

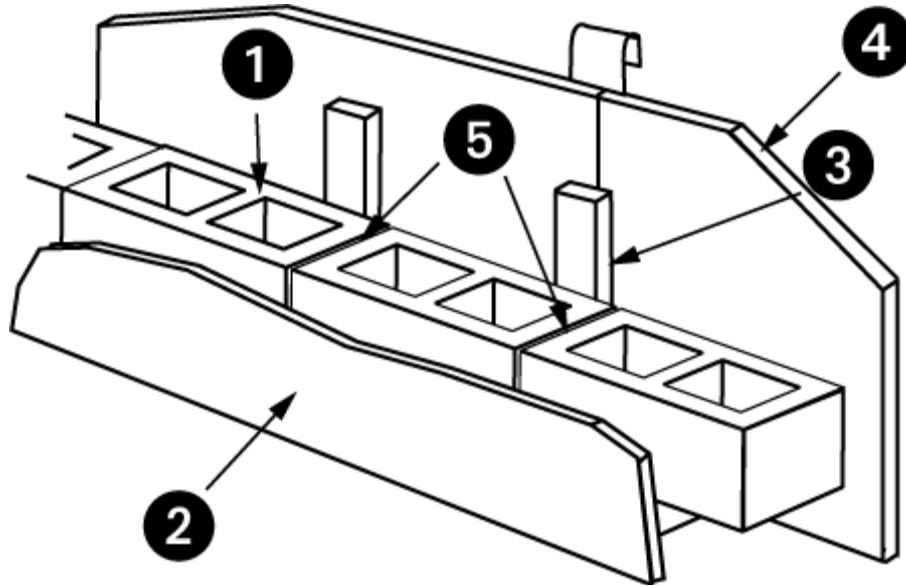

Assembly Information

1. Preferred product 910720 c.m.u. 8" x 8" x 18" nominal
2. Portland cement stucco - 5/8" thick applied directly to C.M.U.
3. Wood or steel furring members - 16" o.c. maximum.
4. Gypsum wallboard - 1/2" thick, long dimension parallel to furring members - all joints finished.
5. ASTM C-270 Masonry Mortar, Type M or S. Face shell or full mortar bedding as required.
6. Masonry grout, reinforcing steel, joint reinforcement, anchors, ties and accessories (Not depicted above - optional). Use where specified.

Preferred Materials Inc. accepts no responsibility for proper application of the rated wall assembly above, or responsibility for the construction of such assemblies.

Fire Rating: 3 Hour No. 8-3-910720SD

Concrete Masonry Unit

Section 3.1 of ACI 216.1

Unit Description	Size WxHxL Nominal	Equivalent Thickness Inches	Fire Rating Minutes
910720	8x8x18	4.1	120.6*

** Linear interpolation from Table 3.1 of ACI 216.1 for Exposed Finish Block Mix – 55% limestone & 45% siliceous aggregates.*

Sections 3.2.2 and 3.2.3

Solid Grouted construction and/or cells filled with loose-fill materials

Included	Equivalent Thickness Inches	Fire Rating Minutes
No	4.1	120.6*
Yes	N/A	N/A

** Linear interpolation from Table 3.1 of ACI 216.1 for Exposed Finish Block Mix – 55% limestone & 45% siliceous aggregates.*

Fire Rating: 3 Hour

No. 8-3-910720SD

Nonfire-exposed side

Side 1

Section 5.2.2 of ACI 216.1

Finish	
5/8 inch thick Portland cement-sand Stucco	.625
Multiplying factor Table 5.1	1
Adjusted Thickness	.625
Concrete Masonry Unit	
Unit Description	910720
Size WxHxL Nominal	8x8x18
Equivalent Thickness	4.1
Fire Rating Minutes	120.6
Total Thickness, CMU + Finish	4.72
Fire Resistance Rating of CMU & Finish, Table 5.1	156*

* Linear interpolation from Table 3.1 of ACI 216.1 for Exposed Finish Block Mix – 55% limestone & 45% siliceous aggregates.

Max. allowable assembly Fire Resistance Block + finishes	180.9
Fire-Resistance Rating of Block and Finish	156

Side 2

Section 5.2.2 of ACI 216.1

Finish	
1/2 inch thick Gypsum Wallboard Type X	.5
Multiplying factor Table 5.1	3
Adjusted Thickness (inches)	1.5
Concrete Masonry Unit	
Unit Description	910720
Size WxHxL Nominal	8x8x18
Equivalent Thickness (inches)	4.1
Fire Rating Minutes	120.6
Total Thickness, CMU + Finish (inches)	5.6
Fire Resistance Rating of CMU & Finish, Table 5.1	210.7*

** Linear interpolation from Table 3.1 of ACI 216.1 for Exposed Finish Block Mix – 55% limestone & 45% siliceous aggregates.*

Max. allowable assembly Fire Resistance Block + finishes	180.9 5.15
Fire-Resistance Rating of Block and Finish	180.9 5.15

Fire Rating: 3 Hour No. 8-3-910720SD

Fire-exposed side

Side 1

Section 5.2.3 of ACI 216.1

Finish	
1/2 inch thick Gypsum Wallboard Type X	
Time assigned to finish materials Table 5.2	25
Fire Resistance of Block and Nonfire-exposed side Finish Table 3.1	156
Assembly Fire-Resistance Rating	181
Max. allowable assembly Fire Resistance Block + finishes	241.2
Total Assembly Fire-Resistance Rating	181

Side 2

Section 5.2.3 of ACI 216.1

Finish	
5/8 inch thick Portland cement-sand Stucco	
Time assigned to finish materials Table 5.2	0 .625
Fire Resistance of Block and Nonfire-exposed side Finish Table 3.1	0 5.15
Assembly Fire-Resistance Rating	222 5.77
Max. allowable assembly Fire Resistance Block + finishes	241.2
Total Assembly Fire-Resistance Rating	222

Assembly Fire-Resistance Rating	181 Minutes
--	--------------------

Fire Resistance Rating, minutes per inches of equivalent thickness
Linear Interpolation from Table 3.1 of ACI 216.1
Exposed Finish Mix - 55% limestone + 45% siliceous aggregates

et	min	et	min	et	min	et	min	et	min	et	min	et	min	et	min	et	min
2.75	60.0	3.16	76.6	3.57	94.0	3.98	114.5	4.39	137.1	4.80	160.5	5.21	184.7	5.62	212.0	6.03	239.4
2.76	60.4	3.17	77.0	3.58	94.5	3.99	115.0	4.40	137.7	4.81	161.1	5.22	185.3	5.63	212.7	6.04	240.0
2.77	60.8	3.18	77.4	3.59	95.0	4.00	115.5	4.41	138.3	4.82	161.7	5.23	186.0	5.64	213.3		
2.78	61.2	3.19	77.8	3.60	95.5	4.01	116.0	4.42	138.8	4.83	162.3	5.24	186.7	5.65	214.0		
2.79	61.6	3.20	78.2	3.61	96.0	4.02	116.5	4.43	139.4	4.84	162.8	5.25	187.3	5.66	214.7		
2.80	62.0	3.21	78.6	3.62	96.5	4.03	117.0	4.44	140.0	4.85	163.4	5.26	188.0	5.67	215.4		
2.81	62.4	3.22	79.0	3.63	97.0	4.04	117.5	4.45	140.6	4.86	164.0	5.27	188.7	5.68	216.0		
2.82	62.8	3.23	79.4	3.64	97.5	4.05	118.0	4.46	141.1	4.87	164.5	5.28	189.3	5.69	216.7		
2.83	63.2	3.24	79.8	3.65	98.0	4.06	118.5	4.47	141.7	4.88	165.1	5.29	190.0	5.70	217.4		
2.84	63.6	3.25	80.2	3.66	98.5	4.07	119.0	4.48	142.3	4.89	165.7	5.30	190.7	5.71	218.0		
2.85	64.0	3.26	80.7	3.67	99.0	4.08	119.5	4.49	142.8	4.90	166.3	5.31	191.3	5.72	218.7		
2.86	64.5	3.27	81.1	3.68	99.5	4.09	120.0	4.50	143.4	4.91	166.8	5.32	192.0	5.73	219.4		
2.87	64.9	3.28	81.5	3.69	100.0	4.10	120.6	4.51	144.0	4.92	167.4	5.33	192.7	5.74	220.0		
2.88	65.3	3.29	81.9	3.70	100.5	4.11	121.1	4.52	144.6	4.93	168.0	5.34	193.3	5.75	220.7		
2.89	65.7	3.30	82.3	3.71	101.0	4.12	121.7	4.53	145.1	4.94	168.5	5.35	194.0	5.76	221.4		
2.90	66.1	3.31	82.7	3.72	101.5	4.13	122.3	4.54	145.7	4.95	169.1	5.36	194.7	5.77	222.0		
2.91	66.5	3.32	83.1	3.73	102.0	4.14	122.9	4.55	146.3	4.96	169.7	5.37	195.3	5.78	222.7		
2.92	66.9	3.33	83.5	3.74	102.5	4.15	123.4	4.56	146.8	4.97	170.2	5.38	196.0	5.79	223.4		
2.93	67.3	3.34	83.9	3.75	103.0	4.16	124.0	4.57	147.4	4.98	170.8	5.39	196.7	5.80	224.0		
2.94	67.7	3.35	84.3	3.76	103.5	4.17	124.6	4.58	148.0	4.99	171.4	5.40	197.3	5.81	224.7		
2.95	68.1	3.36	84.7	3.77	104.0	4.18	125.1	4.59	148.5	5.00	172.0	5.41	198.0	5.82	225.4		
2.96	68.5	3.37	85.1	3.78	104.5	4.19	125.7	4.60	149.1	5.01	172.5	5.42	198.7	5.83	226.0		
2.97	68.9	3.38	85.5	3.79	105.0	4.20	126.3	4.61	149.7	5.02	173.1	5.43	199.3	5.84	226.7		
2.98	69.3	3.39	85.9	3.80	105.5	4.21	126.9	4.62	150.3	5.03	173.7	5.44	200.0	5.85	227.4		
2.99	69.7	3.40	86.3	3.81	106.0	4.22	127.4	4.63	150.8	5.04	174.2	5.45	200.7	5.86	228.0		
3.00	70.1	3.41	86.7	3.82	106.5	4.23	128.0	4.64	151.4	5.05	174.8	5.46	201.3	5.87	228.7		
3.01	70.5	3.42	87.1	3.83	107.0	4.24	128.6	4.65	152.0	5.06	175.4	5.47	202.0	5.88	229.4		
3.02	70.9	3.43	87.5	3.84	107.5	4.25	129.1	4.66	152.5	5.07	176.0	5.48	202.7	5.89	230.0		
3.03	71.3	3.44	87.9	3.85	108.0	4.26	129.7	4.67	153.1	5.08	176.5	5.49	203.3	5.90	230.7		
3.04	71.7	3.45	88.3	3.86	108.5	4.27	130.3	4.68	153.7	5.09	177.1	5.50	204.0	5.91	231.4		
3.05	72.1	3.46	88.8	3.87	109.0	4.28	130.8	4.69	154.3	5.10	177.7	5.51	204.7	5.92	232.0		
3.06	72.6	3.47	89.2	3.88	109.5	4.29	131.4	4.70	154.8	5.11	178.2	5.52	205.3	5.93	232.7		
3.07	73.0	3.48	89.6	3.89	110.0	4.30	132.0	4.71	155.4	5.12	178.8	5.53	206.0	5.94	233.4		
3.08	73.4	3.49	90.0	3.90	110.5	4.31	132.6	4.72	156.0	5.13	179.4	5.54	206.7	5.95	234.0		
3.09	73.8	3.50	90.5	3.91	111.0	4.32	133.1	4.73	156.5	5.14	180.0	5.55	207.3	5.96	234.7		
3.10	74.2	3.51	91.0	3.92	111.5	4.33	133.7	4.74	157.1	5.15	180.7	5.56	208.0	5.97	235.4		
3.11	74.6	3.52	91.5	3.93	112.0	4.34	134.3	4.75	157.7	5.16	181.3	5.57	208.7	5.98	236.0		
3.12	75.0	3.53	92.0	3.94	112.5	4.35	134.8	4.76	158.3	5.17	182.0	5.58	209.3	5.99	236.7		
3.13	75.4	3.54	92.5	3.95	113.0	4.36	135.4	4.77	158.8	5.18	182.7	5.59	210.0	6.00	237.4		
3.14	75.8	3.55	93.0	3.96	113.5	4.37	136.0	4.78	159.4	5.19	183.3	5.60	210.7	6.01	238.0		
3.15	76.2	3.56	93.5	3.97	114.0	4.38	136.6	4.79	160.0	5.20	184.0	5.61	211.3	6.02	238.7		

