

3-Hour Fire Rating

8" C.M.U.

Fire Rating: 3 Hour

No. 8-3-910655SD

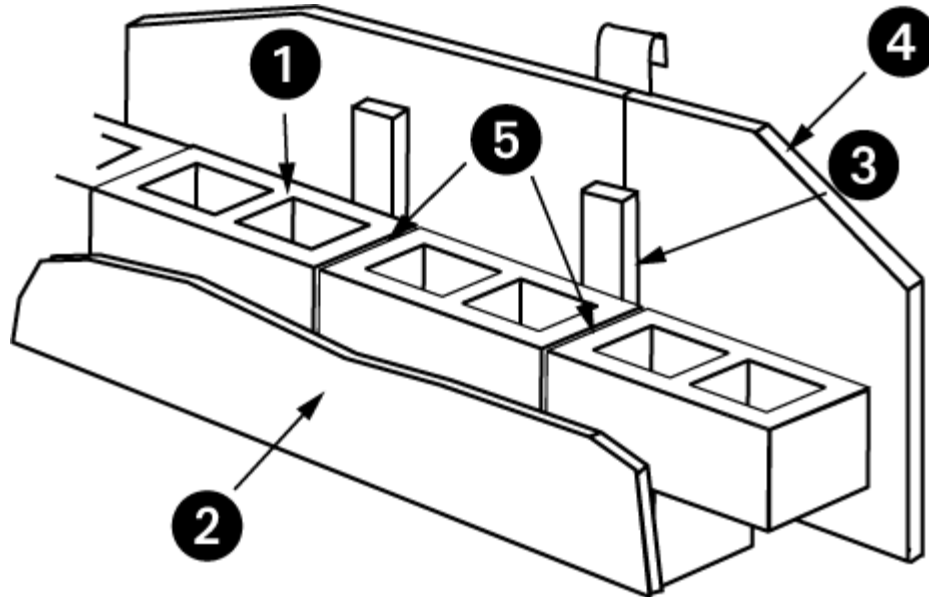

Assembly Information

1. Preferred product 910655 c.m.u. 8" x 8" x 16" nominal
2. Portland cement stucco - 5/8" thick applied directly to C.M.U.
3. Wood or steel furring members - 16" o.c. maximum.
4. Gypsum wallboard – 1/2" thick, both sides, long dimension parallel to furring members – all joints finished.
5. ASTM C-270 Masonry Mortar, Type M or S. Face shell or full mortar bedding as required.
6. Masonry grout, reinforcing steel, joint reinforcement, anchors, ties and accessories (Not depicted above - optional). Use where specified.

Preferred Materials Inc. accepts no responsibility for proper application of the rated wall assembly above, or responsibility for the construction of such assemblies.

Fire Rating: 3 Hour No. 8-3-910655SD

Concrete Masonry Unit

Section 3.1 of ACI 216.1

Unit Description	Size WxHxL Nominal	Equivalent Thickness Inches	Fire Rating Minutes
910655	8x8x16	4.0	120*

** Direct Interpolation from Table 3.1 of ACI 216.1 Stucco/Sand Finish Mix – 100% limestone aggregates*

Sections 3.2.2 and 3.2.3

Solid Grouted construction and/or cells filled with loose-fill materials

Included	Equivalent Thickness Inches	Fire Rating Minutes
No	4.0	120*
Yes	N/A	N/A

** Direct Interpolation from Table 3.1 of ACI 216.1 Stucco/Sand Finish Mix – 100% limestone aggregates*

Fire Rating: 3 Hour

No. 8-3-910655SD

Nonfire-exposed side

Side 1

Section 5.2.2 of ACI 216.1

Finish	
5/8 inch Portland cement-sand Stucco	.625
Multiplying factor Table 5.1	1
Adjusted Thickness	.625
Concrete Masonry Unit	
Unit Description	910655
Size WxHxL Nominal	8x8x16
Equivalent Thickness	4.0
Fire Rating Minutes	120
Total Thickness, CMU + Finish	4.625
Fire Resistance Rating of CMU & Finish, Table 721.3.2	157.2*

** Direct Interpolation from Table 3.1 of ACI 216.1 Stucco/Sand Finish Mix – 100% limestone aggregates*

Max. allowable assembly Fire Resistance Block + finishes	180
Fire-Resistance Rating of Block and Finish	157.2

Side 2

Section 5.2.2 of ACI 216.1

Finish	
1/2 inch thick Gypsum Wallboard Type X	.5
Multiplying factor Table 5.1	3
Adjusted Thickness (inches)	1.5
Concrete Masonry Unit	
Unit Description	910655
Size WxHxL Nominal	8x8x16
Equivalent Thickness (inches)	4.0
Fire Rating Minutes	120
Total Thickness, CMU + Finish (inches)	5.5
Fire Resistance Rating of CMU & Finish, Table 721.3.2	213.3*

** Direct Interpolation from Table 3.1 of ACI 216.1 Stucco/Sand Finish Mix – 100% limestone aggregates*

Max. allowable assembly Fire Resistance Block + finishes	180 5.0
Fire-Resistance Rating of Block and Finish	180 5.0

Fire Rating: 3 Hour No. 8-3-910655SD

Fire-exposed side

Side 1

Section 5.2.3 of ACI 216.1

Finish	
1/2 inch thick Gypsum Wallboard Type X	
Time assigned to finish materials Table 5.2	25
Fire Resistance of Block and Nonfire-exposed side Finish Table 3.1	157.2
Assembly Fire-Resistance Rating	182.2
Max. allowable assembly Fire Resistance Block + finishes	240
Total Assembly Fire-Resistance Rating	182.2

Side 2

Section 5.2.3 of ACI 216.1

Finish	
5/8 inch thick Portland cement-sand Stucco	
Time assigned to finish materials Table 5.2	0 .625
Fire Resistance of Block and Nonfire-exposed side Finish Table 3.1	0 5.0
Assembly Fire-Resistance Rating	221.4 5.625
Max. allowable assembly Fire Resistance Block + finishes	240
Total Assembly Fire-Resistance Rating	221.4

Assembly Fire-Resistance Rating	182.2 Minutes
--	----------------------

Fire Resistance Rating, minutes per inches of equivalent thickness

Direct Interpolation from Table 3.1 of ACI 216.1

Stucco/Sand Finish Mix - 100% limestone aggregates

et	min	et	min	et	min	et	min	et	min	et	min	et	min	et	min
2.70	60.0	3.11	77.5	3.52	96.0	3.93	116.5	4.34	140.4	4.75	165.0	5.16	190.7	5.57	218.0
2.71	60.4	3.12	78.0	3.53	96.5	3.94	117.0	4.35	141.0	4.76	165.6	5.17	191.3	5.58	218.7
2.72	60.9	3.13	78.4	3.54	97.0	3.95	117.5	4.36	141.6	4.77	166.2	5.18	192.0	5.59	219.4
2.73	61.3	3.14	78.8	3.55	97.5	3.96	118.0	4.37	142.2	4.78	166.8	5.19	192.7	5.60	220.0
2.74	61.7	3.15	79.3	3.56	98.0	3.97	118.5	4.38	142.8	4.79	167.4	5.20	193.3	5.61	220.7
2.75	62.1	3.16	79.7	3.57	98.5	3.98	119.0	4.39	143.4	4.80	168.0	5.21	194.0	5.62	221.4
2.76	62.6	3.17	80.1	3.58	99.0	3.99	119.5	4.40	144.0	4.81	168.6	5.22	194.7	5.63	222.0
2.77	63.0	3.18	80.5	3.59	99.5	4.00	120.0	4.41	144.6	4.82	169.2	5.23	195.3	5.64	222.7
2.78	63.4	3.19	81.0	3.60	100.0	4.01	120.6	4.42	145.2	4.83	169.8	5.24	196.0	5.65	223.4
2.79	63.9	3.20	81.4	3.61	100.5	4.02	121.2	4.43	145.8	4.84	170.4	5.25	196.7	5.66	224.0
2.80	64.3	3.21	81.8	3.62	101.0	4.03	121.8	4.44	146.4	4.85	171.0	5.26	197.3	5.67	224.7
2.81	64.7	3.22	82.3	3.63	101.5	4.04	122.4	4.45	147.0	4.86	171.6	5.27	198.0	5.68	225.4
2.82	65.1	3.23	82.7	3.64	102.0	4.05	123.0	4.46	147.6	4.87	172.2	5.28	198.7	5.69	226.0
2.83	65.6	3.24	83.1	3.65	102.5	4.06	123.6	4.47	148.2	4.88	172.8	5.29	199.3	5.70	226.7
2.84	66.0	3.25	83.5	3.66	103.0	4.07	124.2	4.48	148.8	4.89	173.4	5.30	200.0	5.71	227.4
2.85	66.4	3.26	84.0	3.67	103.5	4.08	124.8	4.49	149.4	4.90	174.0	5.31	200.7	5.72	228.0
2.86	66.8	3.27	84.4	3.68	104.0	4.09	125.4	4.50	150.0	4.91	174.6	5.32	201.3	5.73	228.7
2.87	67.3	3.28	84.8	3.69	104.5	4.10	126.0	4.51	150.6	4.92	175.2	5.33	202.0	5.74	229.4
2.88	67.7	3.29	85.3	3.70	105.0	4.11	126.6	4.52	151.2	4.93	175.8	5.34	202.7	5.75	230.0
2.89	68.1	3.30	85.7	3.71	105.5	4.12	127.2	4.53	151.8	4.94	176.4	5.35	203.3	5.76	230.7
2.90	68.6	3.31	86.1	3.72	106.0	4.13	127.8	4.54	152.4	4.95	177.0	5.36	204.0	5.77	231.4
2.91	69.0	3.32	86.5	3.73	106.5	4.14	128.4	4.55	153.0	4.96	177.6	5.37	204.7	5.78	232.0
2.92	69.4	3.33	87.0	3.74	107.0	4.15	129.0	4.56	153.6	4.97	178.2	5.38	205.3	5.79	232.7
2.93	69.8	3.34	87.4	3.75	107.5	4.16	129.6	4.57	154.2	4.98	178.8	5.39	206.0	5.80	233.4
2.94	70.3	3.35	87.8	3.76	108.0	4.17	130.2	4.58	154.8	4.99	179.4	5.40	206.7	5.81	234.0
2.95	70.7	3.36	88.2	3.77	108.5	4.18	130.8	4.59	155.4	5.00	180.0	5.41	207.3	5.82	234.7
2.96	71.1	3.37	88.7	3.78	109.0	4.19	131.4	4.60	156.0	5.01	180.7	5.42	208.0	5.83	235.4
2.97	71.6	3.38	89.1	3.79	109.5	4.20	132.0	4.61	156.6	5.02	181.3	5.43	208.7	5.84	236.0
2.98	72.0	3.39	89.5	3.80	110.0	4.21	132.6	4.62	157.2	5.03	182.0	5.44	209.3	5.85	236.7
2.99	72.4	3.40	90.0	3.81	110.5	4.22	133.2	4.63	157.8	5.04	182.7	5.45	210.0	5.86	237.4
3.00	72.8	3.41	90.5	3.82	111.0	4.23	133.8	4.64	158.4	5.05	183.3	5.46	210.7	5.87	238.0
3.01	73.3	3.42	91.0	3.83	111.5	4.24	134.4	4.65	159.0	5.06	184.0	5.47	211.3	5.88	238.7
3.02	73.7	3.43	91.5	3.84	112.0	4.25	135.0	4.66	159.6	5.07	184.7	5.48	212.0	5.89	239.4
3.03	74.1	3.44	92.0	3.85	112.5	4.26	135.6	4.67	160.2	5.08	185.3	5.49	212.7	5.90	240.0
3.04	74.6	3.45	92.5	3.86	113.0	4.27	136.2	4.68	160.8	5.09	186.0	5.50	213.3		
3.05	75.0	3.46	93.0	3.87	113.5	4.28	136.8	4.69	161.4	5.10	186.7	5.51	214.0		
3.06	75.4	3.47	93.5	3.88	114.0	4.29	137.4	4.70	162.0	5.11	187.3	5.52	214.7		
3.07	75.8	3.48	94.0	3.89	114.5	4.30	138.0	4.71	162.6	5.12	188.0	5.53	215.4		
3.08	76.3	3.49	94.5	3.90	115.0	4.31	138.6	4.72	163.2	5.13	188.7	5.54	216.0		
3.09	76.7	3.50	95.0	3.91	115.5	4.32	139.2	4.73	163.8	5.14	189.3	5.55	216.7		
3.10	77.1	3.51	95.5	3.92	116.0	4.33	139.8	4.74	164.4	5.15	190.0	5.56	217.4		

Fire Resistance Rating, minutes per inches of equivalent thickness
Linear Interpolation from Table 3.1 of ACI 216.1
Exposed Finish Mix - 55% limestone + 45% siliceous aggregates

et	min	et	min	et	min	et	min	et	min	et	min	et	min	et	min	et	min
2.75	60.0	3.16	76.6	3.57	94.0	3.98	114.5	4.39	137.1	4.80	160.5	5.21	184.7	5.62	212.0	6.03	239.4
2.76	60.4	3.17	77.0	3.58	94.5	3.99	115.0	4.40	137.7	4.81	161.1	5.22	185.3	5.63	212.7	6.04	240.0
2.77	60.8	3.18	77.4	3.59	95.0	4.00	115.5	4.41	138.3	4.82	161.7	5.23	186.0	5.64	213.3		
2.78	61.2	3.19	77.8	3.60	95.5	4.01	116.0	4.42	138.8	4.83	162.3	5.24	186.7	5.65	214.0		
2.79	61.6	3.20	78.2	3.61	96.0	4.02	116.5	4.43	139.4	4.84	162.8	5.25	187.3	5.66	214.7		
2.80	62.0	3.21	78.6	3.62	96.5	4.03	117.0	4.44	140.0	4.85	163.4	5.26	188.0	5.67	215.4		
2.81	62.4	3.22	79.0	3.63	97.0	4.04	117.5	4.45	140.6	4.86	164.0	5.27	188.7	5.68	216.0		
2.82	62.8	3.23	79.4	3.64	97.5	4.05	118.0	4.46	141.1	4.87	164.5	5.28	189.3	5.69	216.7		
2.83	63.2	3.24	79.8	3.65	98.0	4.06	118.5	4.47	141.7	4.88	165.1	5.29	190.0	5.70	217.4		
2.84	63.6	3.25	80.2	3.66	98.5	4.07	119.0	4.48	142.3	4.89	165.7	5.30	190.7	5.71	218.0		
2.85	64.0	3.26	80.7	3.67	99.0	4.08	119.5	4.49	142.8	4.90	166.3	5.31	191.3	5.72	218.7		
2.86	64.5	3.27	81.1	3.68	99.5	4.09	120.0	4.50	143.4	4.91	166.8	5.32	192.0	5.73	219.4		
2.87	64.9	3.28	81.5	3.69	100.0	4.10	120.6	4.51	144.0	4.92	167.4	5.33	192.7	5.74	220.0		
2.88	65.3	3.29	81.9	3.70	100.5	4.11	121.1	4.52	144.6	4.93	168.0	5.34	193.3	5.75	220.7		
2.89	65.7	3.30	82.3	3.71	101.0	4.12	121.7	4.53	145.1	4.94	168.5	5.35	194.0	5.76	221.4		
2.90	66.1	3.31	82.7	3.72	101.5	4.13	122.3	4.54	145.7	4.95	169.1	5.36	194.7	5.77	222.0		
2.91	66.5	3.32	83.1	3.73	102.0	4.14	122.9	4.55	146.3	4.96	169.7	5.37	195.3	5.78	222.7		
2.92	66.9	3.33	83.5	3.74	102.5	4.15	123.4	4.56	146.8	4.97	170.2	5.38	196.0	5.79	223.4		
2.93	67.3	3.34	83.9	3.75	103.0	4.16	124.0	4.57	147.4	4.98	170.8	5.39	196.7	5.80	224.0		
2.94	67.7	3.35	84.3	3.76	103.5	4.17	124.6	4.58	148.0	4.99	171.4	5.40	197.3	5.81	224.7		
2.95	68.1	3.36	84.7	3.77	104.0	4.18	125.1	4.59	148.5	5.00	172.0	5.41	198.0	5.82	225.4		
2.96	68.5	3.37	85.1	3.78	104.5	4.19	125.7	4.60	149.1	5.01	172.5	5.42	198.7	5.83	226.0		
2.97	68.9	3.38	85.5	3.79	105.0	4.20	126.3	4.61	149.7	5.02	173.1	5.43	199.3	5.84	226.7		
2.98	69.3	3.39	85.9	3.80	105.5	4.21	126.9	4.62	150.3	5.03	173.7	5.44	200.0	5.85	227.4		
2.99	69.7	3.40	86.3	3.81	106.0	4.22	127.4	4.63	150.8	5.04	174.2	5.45	200.7	5.86	228.0		
3.00	70.1	3.41	86.7	3.82	106.5	4.23	128.0	4.64	151.4	5.05	174.8	5.46	201.3	5.87	228.7		
3.01	70.5	3.42	87.1	3.83	107.0	4.24	128.6	4.65	152.0	5.06	175.4	5.47	202.0	5.88	229.4		
3.02	70.9	3.43	87.5	3.84	107.5	4.25	129.1	4.66	152.5	5.07	176.0	5.48	202.7	5.89	230.0		
3.03	71.3	3.44	87.9	3.85	108.0	4.26	129.7	4.67	153.1	5.08	176.5	5.49	203.3	5.90	230.7		
3.04	71.7	3.45	88.3	3.86	108.5	4.27	130.3	4.68	153.7	5.09	177.1	5.50	204.0	5.91	231.4		
3.05	72.1	3.46	88.8	3.87	109.0	4.28	130.8	4.69	154.3	5.10	177.7	5.51	204.7	5.92	232.0		
3.06	72.6	3.47	89.2	3.88	109.5	4.29	131.4	4.70	154.8	5.11	178.2	5.52	205.3	5.93	232.7		
3.07	73.0	3.48	89.6	3.89	110.0	4.30	132.0	4.71	155.4	5.12	178.8	5.53	206.0	5.94	233.4		
3.08	73.4	3.49	90.0	3.90	110.5	4.31	132.6	4.72	156.0	5.13	179.4	5.54	206.7	5.95	234.0		
3.09	73.8	3.50	90.5	3.91	111.0	4.32	133.1	4.73	156.5	5.14	180.0	5.55	207.3	5.96	234.7		
3.10	74.2	3.51	91.0	3.92	111.5	4.33	133.7	4.74	157.1	5.15	180.7	5.56	208.0	5.97	235.4		
3.11	74.6	3.52	91.5	3.93	112.0	4.34	134.3	4.75	157.7	5.16	181.3	5.57	208.7	5.98	236.0		
3.12	75.0	3.53	92.0	3.94	112.5	4.35	134.8	4.76	158.3	5.17	182.0	5.58	209.3	5.99	236.7		
3.13	75.4	3.54	92.5	3.95	113.0	4.36	135.4	4.77	158.8	5.18	182.7	5.59	210.0	6.00	237.4		
3.14	75.8	3.55	93.0	3.96	113.5	4.37	136.0	4.78	159.4	5.19	183.3	5.60	210.7	6.01	238.0		
3.15	76.2	3.56	93.5	3.97	114.0	4.38	136.6	4.79	160.0	5.20	184.0	5.61	211.3	6.02	238.7		