

## 2-Hour Fire Rating

8" C.M.U.

Fire Rating: 2 Hour

No. 8-2-910635S

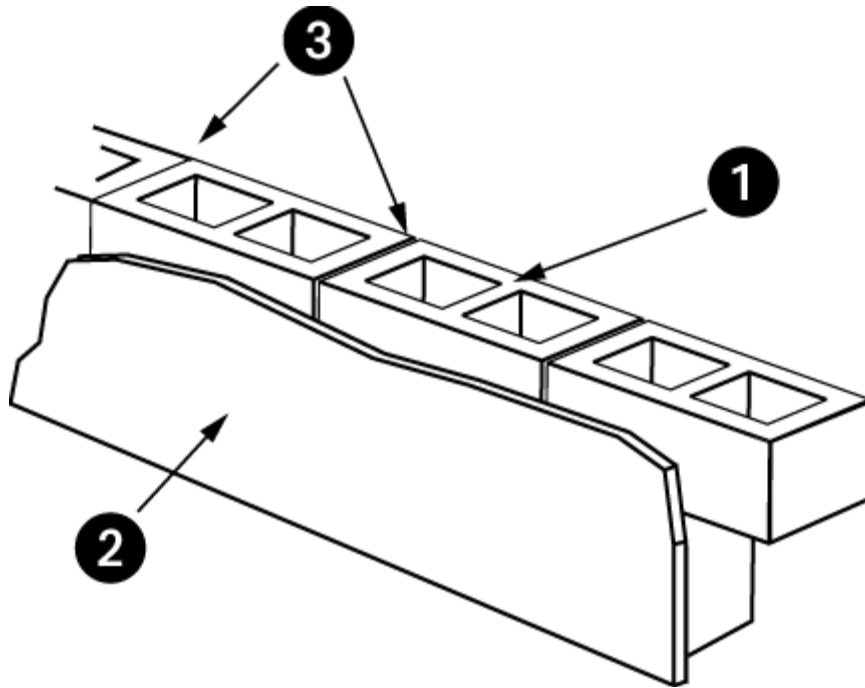

### Assembly Information

1. Preferred product 910635 c.m.u. 8" x 8" x 16" nominal
2. Portland cement stucco - 1/2" thick applied directly to C.M.U.
2. ASTM C-270 Masonry Mortar, Type M or S. Face shell or full mortar bedding as required.
3. Masonry grout, reinforcing steel, joint reinforcement, anchors, ties and accessories (Not depicted above - optional). Use where specified.

***Preferred Materials Inc. accepts no responsibility for proper application of the rated wall assembly above, or responsibility for the construction of such assemblies.***

**Fire Rating: 2 Hour      No. 8-2-910635S**

## **Concrete Masonry Unit**

**Section 721.3.2 of the Florida Building Code**

| <b>Unit Description</b> | <b>Size<br/>WxHxL Nominal</b> | <b>Equivalent<br/>Thickness Inches</b> | <b>Fire Rating Minutes</b> |
|-------------------------|-------------------------------|----------------------------------------|----------------------------|
| <b>910635</b>           | <b>8x8x16</b>                 | <b>3.6</b>                             | <b>95.5*</b>               |

*\* Linear interpolation from Table 721.3.2 of the Florida Building Code for Exposed Finish Block Mix – 55% limestone & 45% siliceous aggregates.*

**Section 721.3.1.3 and 721.3.1.4 of the Florida Building Code**

**Solid Grouted construction and/or cells filled with loose-fill materials**

| <b>Included</b> | <b>Equivalent<br/>Thickness Inches</b> | <b>Fire Rating<br/>Minutes</b> |
|-----------------|----------------------------------------|--------------------------------|
| <b>No</b>       | <b>3.6</b>                             | <b>95.5</b>                    |
| <b>Yes</b>      | <b>N/A</b>                             | <b>N/A</b>                     |

*\* Linear interpolation from Table 721.3.2 of the Florida Building Code for Exposed Finish Block Mix – 55% limestone & 45% siliceous aggregates.*

**Fire Rating: 2 Hour      No. 8-2-910635S**

**Nonfire-exposed side**

**Side 1**

**Section 721.3.2.1 of the Florida Building Code**

| Finish                                                |        |
|-------------------------------------------------------|--------|
| ½ inch thick Portland cement-sand Stucco              | 0.5    |
| Multiplying factor Table 721.2.1.4(1)                 | 1      |
| Adjusted Thickness                                    | 0.5    |
| Concrete Masonry Unit                                 |        |
| Unit Description                                      | 910635 |
| Size WxHxL Nominal                                    | 8x8x16 |
| Equivalent Thickness                                  | 3.6    |
| Fire Rating Minutes                                   | 95.5   |
| Total Thickness, CMU + Finish                         | 4.1    |
| Fire Resistance Rating of CMU & Finish, Table 721.3.2 | 120.5* |

*\* Linear interpolation from Table 721.3.2 of the Florida Building Code for Exposed Finish Block Mix – 55% limestone & 45% siliceous aggregates.*

**Side 2**

**Section 721.3.2.1 of the Florida Building Code**

| Finish                                                |        |
|-------------------------------------------------------|--------|
| None                                                  | 0      |
| Multiplying factor Table 721.2.1.4(1)                 | N/A    |
| Adjusted Thickness (inches)                           | 0      |
| Concrete Masonry Unit                                 |        |
| Unit Description                                      | 910635 |
| Size WxHxL Nominal                                    | 8x8x16 |
| Equivalent Thickness (inches)                         | 3.6    |
| Fire Rating Minutes                                   | 95.5   |
| Total Thickness, CMU + Finish (inches)                | 3.6    |
| Fire Resistance Rating of CMU & Finish, Table 721.3.2 | 95.5*  |

*\* Linear interpolation from Table 721.3.2 of the Florida Building Code for Exposed Finish Block Mix – 55% limestone & 45% siliceous aggregates.*

**Fire Rating: 2 Hour      No. 8-2-910635S**

**Fire-exposed side**

**Side 1**

**Section 721.3.2.2 of the Florida Building Code**

| <b>Finish</b>                                                               |              |
|-----------------------------------------------------------------------------|--------------|
| <b>None</b>                                                                 |              |
| <b>Time assigned to finish materials Table 721.2.1.4(2)</b>                 | <b>0</b>     |
|                                                                             |              |
| <b>Fire Resistance of CMU and Nonfire-exposed side Finish Table 721.3.2</b> | <b>120.5</b> |
|                                                                             |              |
| <b>Assembly Fire-Resistance Rating</b>                                      | <b>120.5</b> |
|                                                                             |              |
| <b>Max. allowable assembly Fire Resistance Block + finishes</b>             | <b>191</b>   |
|                                                                             |              |
| <b>Total Assembly Fire-Resistance Rating</b>                                | <b>120.5</b> |

**Side 2**

**Section 721.3.2.2 of the Florida Building Code**

| <b>Finish</b>                                                               |                      |
|-----------------------------------------------------------------------------|----------------------|
| <b>½ inch thick Portland cement-sand Stucco</b>                             |                      |
| <b>Time assigned to finish materials Table 721.2.1.4(2)</b>                 | <b>0<br/>0.5</b>     |
|                                                                             |                      |
| <b>Fire Resistance of CMU and Nonfire-exposed side Finish Table 721.3.2</b> | <b>0<br/>3.6</b>     |
|                                                                             |                      |
| <b>Assembly Fire-Resistance Rating</b>                                      | <b>120.5<br/>4.1</b> |
|                                                                             |                      |
| <b>Max. allowable assembly Fire Resistance Block + finishes</b>             | <b>191</b>           |
|                                                                             |                      |
| <b>Total Assembly Fire-Resistance Rating</b>                                | <b>120.5</b>         |

|                                        |                      |
|----------------------------------------|----------------------|
| <b>Assembly Fire-Resistance Rating</b> | <b>120.5 Minutes</b> |
|----------------------------------------|----------------------|

**Fire Resistance Rating, minutes per inches of equivalent thickness  
Linear Interpolation from table 721.3.2 of the 2007 Florida Building Code  
Exposed Finish Block Mix – 55% Limestone & 45% Siliceous Aggregates**

|      |      |      |      |      |      |      |      |      |       |      |       |      |       |      |       |      |       |      |       |
|------|------|------|------|------|------|------|------|------|-------|------|-------|------|-------|------|-------|------|-------|------|-------|
| 1.95 | 30.0 | 2.36 | 45.4 | 2.77 | 60.8 | 3.18 | 76.3 | 3.59 | 95.0  | 4.00 | 115.5 | 4.41 | 136.2 | 4.82 | 160.8 | 5.23 | 186.8 | 5.64 | 210.0 |
| 1.96 | 30.4 | 2.37 | 45.8 | 2.78 | 61.1 | 3.19 | 76.8 | 3.60 | 95.5  | 4.01 | 116.0 | 4.42 | 136.8 | 4.83 | 161.4 | 5.24 | 187.5 | 5.65 | 210.8 |
| 1.97 | 30.8 | 2.38 | 46.1 | 2.79 | 61.5 | 3.20 | 77.2 | 3.61 | 96.0  | 4.02 | 116.5 | 4.43 | 137.4 | 4.84 | 162.0 | 5.25 | 188.3 | 5.66 | 211.5 |
| 1.98 | 31.1 | 2.39 | 46.5 | 2.80 | 61.9 | 3.21 | 77.6 | 3.62 | 96.5  | 4.03 | 117.0 | 4.44 | 138.0 | 4.85 | 162.6 | 5.26 | 189.0 | 5.67 | 212.3 |
| 1.99 | 31.5 | 2.40 | 46.9 | 2.81 | 62.3 | 3.22 | 78.1 | 3.63 | 97.0  | 4.04 | 117.5 | 4.45 | 138.6 | 4.86 | 163.2 | 5.27 | 189.8 | 5.68 | 213.0 |
| 2.00 | 31.9 | 2.41 | 47.3 | 2.82 | 62.6 | 3.23 | 78.5 | 3.64 | 97.5  | 4.05 | 118.0 | 4.46 | 139.2 | 4.87 | 163.8 | 5.28 | 190.5 | 5.69 | 213.8 |
| 2.01 | 32.3 | 2.42 | 47.6 | 2.83 | 63.0 | 3.24 | 79.0 | 3.65 | 98.0  | 4.06 | 118.5 | 4.47 | 139.8 | 4.88 | 164.4 | 5.29 | 191.3 | 5.70 | 214.5 |
| 2.02 | 32.6 | 2.43 | 48.0 | 2.84 | 63.4 | 3.25 | 79.4 | 3.66 | 98.5  | 4.07 | 119.0 | 4.48 | 140.4 | 4.89 | 165.0 | 5.30 | 192.0 | 5.71 | 215.3 |
| 2.03 | 33.0 | 2.44 | 48.4 | 2.85 | 63.7 | 3.26 | 79.9 | 3.67 | 99.0  | 4.08 | 119.5 | 4.49 | 141.0 | 4.90 | 165.6 | 5.31 | 192.8 | 5.72 | 216.0 |
| 2.04 | 33.4 | 2.45 | 48.7 | 2.86 | 64.1 | 3.27 | 80.3 | 3.68 | 99.5  | 4.09 | 120.0 | 4.50 | 141.6 | 4.91 | 166.2 | 5.32 | 193.5 | 5.73 | 216.8 |
| 2.05 | 33.8 | 2.46 | 49.1 | 2.87 | 64.5 | 3.28 | 80.7 | 3.69 | 100.0 | 4.10 | 120.5 | 4.51 | 142.2 | 4.92 | 166.8 | 5.33 | 194.3 | 5.74 | 217.5 |
| 2.06 | 34.1 | 2.47 | 49.5 | 2.88 | 64.9 | 3.29 | 81.2 | 3.70 | 100.5 | 4.11 | 121.0 | 4.52 | 142.8 | 4.93 | 167.4 | 5.34 | 195.0 | 5.75 | 218.3 |
| 2.07 | 34.5 | 2.48 | 49.9 | 2.89 | 65.2 | 3.30 | 81.6 | 3.71 | 101.0 | 4.12 | 121.5 | 4.53 | 143.4 | 4.94 | 168.0 | 5.35 | 195.5 | 5.76 | 219.0 |
| 2.08 | 34.9 | 2.49 | 50.2 | 2.90 | 65.6 | 3.31 | 82.1 | 3.72 | 101.5 | 4.13 | 122.0 | 4.54 | 144.0 | 4.95 | 168.6 | 5.36 | 196.0 | 5.77 | 219.8 |
| 2.09 | 35.2 | 2.50 | 50.6 | 2.91 | 66.0 | 3.32 | 82.5 | 3.73 | 102.0 | 4.14 | 122.5 | 4.55 | 144.6 | 4.96 | 169.2 | 5.37 | 196.5 | 5.78 | 220.5 |
| 2.10 | 35.6 | 2.51 | 51.0 | 2.92 | 66.4 | 3.33 | 82.9 | 3.74 | 102.5 | 4.15 | 123.0 | 4.56 | 145.2 | 4.97 | 169.8 | 5.38 | 197.0 | 5.79 | 221.3 |
| 2.11 | 36.0 | 2.52 | 51.4 | 2.93 | 66.7 | 3.34 | 83.4 | 3.75 | 103.0 | 4.16 | 123.5 | 4.57 | 145.8 | 4.98 | 170.4 | 5.39 | 197.5 | 5.80 | 222.0 |
| 2.12 | 36.4 | 2.53 | 51.7 | 2.94 | 67.1 | 3.35 | 83.8 | 3.76 | 103.5 | 4.17 | 124.0 | 4.58 | 146.4 | 4.99 | 171.0 | 5.40 | 198.0 | 5.81 | 222.8 |
| 2.13 | 36.7 | 2.54 | 52.1 | 2.95 | 67.5 | 3.36 | 84.3 | 3.77 | 104.0 | 4.18 | 124.5 | 4.59 | 147.0 | 5.00 | 171.6 | 5.41 | 198.5 | 5.82 | 223.5 |
| 2.14 | 37.1 | 2.55 | 52.5 | 2.96 | 67.9 | 3.37 | 84.7 | 3.78 | 104.5 | 4.19 | 125.0 | 4.60 | 147.6 | 5.01 | 172.2 | 5.42 | 199.0 | 5.83 | 224.3 |
| 2.15 | 37.5 | 2.56 | 52.9 | 2.97 | 68.2 | 3.38 | 85.1 | 3.79 | 105.0 | 4.20 | 125.5 | 4.61 | 148.2 | 5.02 | 172.8 | 5.43 | 199.5 | 5.84 | 225.0 |
| 2.16 | 37.9 | 2.57 | 53.2 | 2.98 | 68.6 | 3.39 | 85.6 | 3.80 | 105.5 | 4.21 | 126.0 | 4.62 | 148.8 | 5.03 | 173.4 | 5.44 | 200.0 | 5.85 | 225.8 |
| 2.17 | 38.2 | 2.58 | 53.6 | 2.99 | 69.0 | 3.40 | 86.0 | 3.81 | 106.0 | 4.22 | 126.5 | 4.63 | 149.4 | 5.04 | 174.0 | 5.45 | 200.5 | 5.86 | 226.5 |
| 2.18 | 38.6 | 2.59 | 54.0 | 3.00 | 69.4 | 3.41 | 86.5 | 3.82 | 106.5 | 4.23 | 127.0 | 4.64 | 150.0 | 5.05 | 174.6 | 5.46 | 201.0 | 5.87 | 227.3 |
| 2.19 | 39.0 | 2.60 | 54.4 | 3.01 | 69.7 | 3.42 | 86.9 | 3.83 | 107.0 | 4.24 | 127.5 | 4.65 | 150.6 | 5.06 | 175.2 | 5.47 | 201.5 | 5.88 | 228.0 |
| 2.20 | 39.4 | 2.61 | 54.7 | 3.02 | 70.1 | 3.43 | 87.3 | 3.84 | 107.5 | 4.25 | 128.0 | 4.66 | 151.2 | 5.07 | 175.8 | 5.48 | 202.0 | 5.89 | 228.8 |
| 2.21 | 39.7 | 2.62 | 55.1 | 3.03 | 70.5 | 3.44 | 87.8 | 3.85 | 108.0 | 4.26 | 128.5 | 4.67 | 151.8 | 5.08 | 176.4 | 5.49 | 202.5 | 5.90 | 229.5 |
| 2.22 | 40.1 | 2.63 | 55.5 | 3.04 | 70.9 | 3.45 | 88.2 | 3.86 | 108.5 | 4.27 | 129.0 | 4.68 | 152.4 | 5.09 | 177.0 | 5.50 | 203.0 | 5.91 | 230.3 |
| 2.23 | 40.5 | 2.64 | 55.9 | 3.05 | 71.2 | 3.46 | 88.7 | 3.87 | 109.0 | 4.28 | 129.5 | 4.69 | 153.0 | 5.10 | 177.6 | 5.51 | 203.5 | 5.92 | 231.0 |
| 2.24 | 40.9 | 2.65 | 56.2 | 3.06 | 71.6 | 3.47 | 89.1 | 3.88 | 109.5 | 4.29 | 130.0 | 4.70 | 153.6 | 5.11 | 178.2 | 5.52 | 204.0 | 5.93 | 231.8 |
| 2.25 | 41.2 | 2.66 | 56.6 | 3.07 | 72.0 | 3.48 | 89.6 | 3.89 | 110.0 | 4.30 | 130.5 | 4.71 | 154.2 | 5.12 | 178.8 | 5.53 | 204.5 | 5.94 | 232.5 |
| 2.26 | 41.6 | 2.67 | 57.0 | 3.08 | 72.4 | 3.49 | 90.0 | 3.90 | 110.5 | 4.31 | 131.0 | 4.72 | 154.8 | 5.13 | 179.4 | 5.54 | 205.0 | 5.95 | 233.3 |
| 2.27 | 42.0 | 2.68 | 57.4 | 3.09 | 72.7 | 3.50 | 90.5 | 3.91 | 111.0 | 4.32 | 131.5 | 4.73 | 155.4 | 5.14 | 180.0 | 5.55 | 205.5 | 5.96 | 234.0 |
| 2.28 | 42.4 | 2.69 | 57.7 | 3.10 | 73.1 | 3.51 | 91.0 | 3.92 | 111.5 | 4.33 | 132.0 | 4.74 | 156.0 | 5.15 | 180.8 | 5.56 | 206.0 | 5.97 | 234.8 |
| 2.29 | 42.7 | 2.70 | 58.1 | 3.11 | 73.5 | 3.52 | 91.5 | 3.93 | 112.0 | 4.34 | 132.5 | 4.75 | 156.6 | 5.16 | 181.5 | 5.57 | 206.5 | 5.98 | 235.5 |
| 2.30 | 43.1 | 2.71 | 58.5 | 3.12 | 73.9 | 3.53 | 92.0 | 3.94 | 112.5 | 4.35 | 133.0 | 4.76 | 157.2 | 5.17 | 182.3 | 5.58 | 207.0 | 5.99 | 236.3 |
| 2.31 | 43.5 | 2.72 | 58.9 | 3.13 | 74.2 | 3.54 | 92.5 | 3.95 | 113.0 | 4.36 | 133.5 | 4.77 | 157.8 | 5.18 | 183.0 | 5.59 | 207.5 | 6.00 | 237.0 |
| 2.32 | 43.9 | 2.73 | 59.2 | 3.14 | 74.6 | 3.55 | 93.0 | 3.96 | 113.5 | 4.37 | 134.0 | 4.78 | 158.4 | 5.19 | 183.8 | 5.60 | 208.0 | 6.01 | 237.8 |
| 2.33 | 44.2 | 2.74 | 59.6 | 3.15 | 75.0 | 3.56 | 93.5 | 3.97 | 114.0 | 4.38 | 134.5 | 4.79 | 159.0 | 5.20 | 184.5 | 5.61 | 208.5 | 6.02 | 238.5 |
| 2.34 | 44.6 | 2.75 | 60.0 | 3.16 | 75.4 | 3.57 | 94.0 | 3.98 | 114.5 | 4.39 | 135.0 | 4.80 | 159.6 | 5.21 | 185.3 | 5.62 | 209.0 | 6.03 | 239.3 |
| 2.35 | 45.0 | 2.76 | 60.4 | 3.17 | 75.9 | 3.58 | 94.5 | 3.99 | 115.0 | 4.40 | 135.6 | 4.81 | 160.2 | 5.22 | 186.0 | 5.63 | 209.5 | 6.04 | 240.0 |

**Fire Resistance Rating, minutes per inches of equivalent thickness  
Direct Interpolation from table 721.3.2 of the 2007 Florida Building Code  
Stucco/Sand Finish Block Mix – 100% Limestone**

| et   | min  | et   | min  | et   | min  | et   | min  | et   | min   | et   | min   | et   | min   | et   | min   | et   | min   | et   | min   | et   | min   |
|------|------|------|------|------|------|------|------|------|-------|------|-------|------|-------|------|-------|------|-------|------|-------|------|-------|
| 1.90 | 30.0 | 2.31 | 45.4 | 2.72 | 60.8 | 3.13 | 76.5 | 3.54 | 92.0  | 3.95 | 107.5 | 4.36 | 123.0 | 4.77 | 138.5 | 5.18 | 154.0 | 5.59 | 169.5 | 6.00 | 185.0 |
| 1.91 | 30.4 | 2.32 | 45.8 | 2.73 | 61.1 | 3.14 | 77.0 | 3.55 | 92.5  | 3.96 | 108.0 | 4.37 | 123.5 | 4.78 | 139.0 | 5.19 | 154.5 | 5.60 | 170.0 | 6.01 | 185.5 |
| 1.92 | 30.8 | 2.33 | 46.1 | 2.74 | 61.5 | 3.15 | 77.5 | 3.56 | 93.0  | 3.97 | 108.5 | 4.38 | 124.0 | 4.79 | 139.5 | 5.20 | 155.0 | 5.61 | 170.5 | 6.02 | 186.0 |
| 1.93 | 31.1 | 2.34 | 46.5 | 2.75 | 61.9 | 3.16 | 78.0 | 3.57 | 93.5  | 3.98 | 109.0 | 4.39 | 124.5 | 4.80 | 140.0 | 5.21 | 155.5 | 5.62 | 171.0 | 6.03 | 186.5 |
| 1.94 | 31.5 | 2.35 | 46.9 | 2.76 | 62.3 | 3.17 | 78.5 | 3.58 | 94.0  | 3.99 | 109.5 | 4.40 | 125.0 | 4.81 | 140.5 | 5.22 | 156.0 | 5.63 | 171.5 | 6.04 | 187.0 |
| 1.95 | 31.9 | 2.36 | 47.3 | 2.77 | 62.6 | 3.18 | 79.0 | 3.59 | 94.5  | 4.00 | 110.0 | 4.41 | 125.5 | 4.82 | 141.0 | 5.23 | 156.5 | 5.64 | 172.0 | 6.05 | 187.5 |
| 1.96 | 32.3 | 2.37 | 47.6 | 2.78 | 63.0 | 3.19 | 79.5 | 3.60 | 95.0  | 4.01 | 110.5 | 4.42 | 126.0 | 4.83 | 141.5 | 5.24 | 157.0 | 5.65 | 172.5 | 6.06 | 188.0 |
| 1.97 | 32.6 | 2.38 | 48.0 | 2.79 | 63.4 | 3.20 | 80.0 | 3.61 | 95.5  | 4.02 | 111.0 | 4.43 | 126.5 | 4.84 | 142.0 | 5.25 | 157.5 | 5.66 | 173.0 | 6.07 | 188.5 |
| 1.98 | 33.0 | 2.39 | 48.4 | 2.80 | 63.7 | 3.21 | 80.5 | 3.62 | 96.0  | 4.03 | 111.5 | 4.44 | 127.0 | 4.85 | 142.5 | 5.26 | 158.0 | 5.67 | 173.5 | 6.08 | 189.0 |
| 1.99 | 33.4 | 2.40 | 48.8 | 2.81 | 64.1 | 3.22 | 81.0 | 3.63 | 96.5  | 4.04 | 112.0 | 4.45 | 127.5 | 4.86 | 143.0 | 5.27 | 158.5 | 5.68 | 174.0 | 6.09 | 189.5 |
| 2.00 | 33.8 | 2.41 | 49.1 | 2.82 | 64.5 | 3.23 | 81.5 | 3.64 | 97.0  | 4.05 | 112.5 | 4.46 | 128.0 | 4.87 | 143.5 | 5.28 | 159.0 | 5.69 | 174.5 | 6.10 | 190.0 |
| 2.01 | 34.1 | 2.42 | 49.5 | 2.83 | 64.9 | 3.24 | 82.0 | 3.65 | 97.5  | 4.06 | 113.0 | 4.47 | 128.5 | 4.88 | 144.0 | 5.29 | 159.5 | 5.70 | 175.0 | 6.11 | 190.5 |
| 2.02 | 34.5 | 2.43 | 49.9 | 2.84 | 65.2 | 3.25 | 82.5 | 3.66 | 98.0  | 4.07 | 113.5 | 4.48 | 129.0 | 4.89 | 144.5 | 5.30 | 160.0 | 5.71 | 175.5 | 6.12 | 191.0 |
| 2.03 | 34.9 | 2.44 | 50.3 | 2.85 | 65.6 | 3.26 | 83.0 | 3.67 | 98.5  | 4.08 | 114.0 | 4.49 | 129.5 | 4.90 | 145.0 | 5.31 | 160.5 | 5.72 | 176.0 | 6.13 | 191.5 |
| 2.04 | 35.3 | 2.45 | 50.6 | 2.86 | 66.0 | 3.27 | 83.5 | 3.68 | 99.0  | 4.09 | 114.5 | 4.50 | 130.0 | 4.91 | 145.5 | 5.32 | 161.0 | 5.73 | 176.5 | 6.14 | 192.0 |
| 2.05 | 35.6 | 2.46 | 51.0 | 2.87 | 66.4 | 3.28 | 84.0 | 3.69 | 99.5  | 4.10 | 115.0 | 4.51 | 130.5 | 4.92 | 146.0 | 5.33 | 161.5 | 5.74 | 177.0 | 6.15 | 192.5 |
| 2.06 | 36.0 | 2.47 | 51.4 | 2.88 | 66.7 | 3.29 | 84.5 | 3.70 | 100.0 | 4.11 | 115.5 | 4.52 | 131.0 | 4.93 | 146.5 | 5.34 | 162.0 | 5.75 | 177.5 | 6.16 | 193.0 |
| 2.07 | 36.4 | 2.48 | 51.7 | 2.89 | 67.1 | 3.30 | 85.0 | 3.71 | 100.5 | 4.12 | 116.0 | 4.53 | 131.5 | 4.94 | 147.0 | 5.35 | 162.5 | 5.76 | 178.0 | 6.17 | 193.5 |
| 2.08 | 36.7 | 2.49 | 52.1 | 2.90 | 67.5 | 3.31 | 85.5 | 3.72 | 101.0 | 4.13 | 116.5 | 4.54 | 132.0 | 4.95 | 147.5 | 5.36 | 163.0 | 5.77 | 178.5 | 6.18 | 194.0 |
| 2.09 | 37.1 | 2.50 | 52.5 | 2.91 | 67.9 | 3.32 | 86.0 | 3.73 | 101.5 | 4.14 | 117.0 | 4.55 | 132.5 | 4.96 | 148.0 | 5.37 | 163.5 | 5.78 | 179.0 | 6.19 | 194.5 |
| 2.10 | 37.5 | 2.51 | 52.9 | 2.92 | 68.2 | 3.33 | 86.5 | 3.74 | 102.0 | 4.15 | 117.5 | 4.56 | 133.0 | 4.97 | 148.5 | 5.38 | 164.0 | 5.79 | 179.5 | 6.20 | 195.0 |
| 2.11 | 37.9 | 2.52 | 53.2 | 2.93 | 68.6 | 3.34 | 87.0 | 3.75 | 102.5 | 4.16 | 118.0 | 4.57 | 133.5 | 4.98 | 149.0 | 5.39 | 164.5 | 5.80 | 180.0 | 6.21 | 195.5 |
| 2.12 | 38.2 | 2.53 | 53.6 | 2.94 | 69.0 | 3.35 | 87.5 | 3.76 | 103.0 | 4.17 | 118.5 | 4.58 | 134.0 | 4.99 | 149.5 | 5.40 | 165.0 | 5.81 | 180.5 | 6.22 | 196.0 |
| 2.13 | 38.6 | 2.54 | 54.0 | 2.95 | 69.4 | 3.36 | 88.0 | 3.77 | 103.5 | 4.18 | 119.0 | 4.59 | 134.5 | 5.00 | 150.0 | 5.41 | 165.5 | 5.82 | 181.0 | 6.23 | 196.5 |
| 2.14 | 39.0 | 2.55 | 54.4 | 2.96 | 69.7 | 3.37 | 88.5 | 3.78 | 104.0 | 4.19 | 119.5 | 4.60 | 135.0 | 5.01 | 150.5 | 5.42 | 166.0 | 5.83 | 181.5 | 6.24 | 197.0 |
| 2.15 | 39.4 | 2.56 | 54.7 | 2.97 | 70.1 | 3.38 | 89.0 | 3.79 | 104.5 | 4.20 | 120.0 | 4.61 | 135.5 | 5.02 | 151.0 | 5.43 | 166.5 | 5.84 | 182.0 | 6.25 | 197.5 |
| 2.16 | 39.7 | 2.57 | 55.1 | 2.98 | 70.5 | 3.39 | 89.5 | 3.80 | 105.0 | 4.21 | 120.5 | 4.62 | 136.0 | 5.03 | 151.5 | 5.44 | 167.0 | 5.85 | 182.5 | 6.26 | 198.0 |
| 2.17 | 40.1 | 2.58 | 55.5 | 2.99 | 70.9 | 3.40 | 90.0 | 3.81 | 105.5 | 4.22 | 121.0 | 4.63 | 136.5 | 5.04 | 152.0 | 5.45 | 167.5 | 5.86 | 183.0 | 6.27 | 198.5 |
| 2.18 | 40.5 | 2.59 | 55.9 | 3.00 | 71.2 | 3.41 | 90.5 | 3.82 | 106.0 | 4.23 | 121.5 | 4.64 | 137.0 | 5.05 | 152.5 | 5.46 | 168.0 | 5.87 | 183.5 | 6.28 | 199.0 |
| 2.19 | 40.9 | 2.60 | 56.2 | 3.01 | 71.6 | 3.42 | 91.0 | 3.83 | 106.5 | 4.24 | 122.0 | 4.65 | 137.5 | 5.06 | 153.0 | 5.47 | 168.5 | 5.88 | 184.0 | 6.29 | 199.5 |
| 2.20 | 41.2 | 2.61 | 56.6 | 3.02 | 72.0 | 3.43 | 91.5 | 3.84 | 107.0 | 4.25 | 122.5 | 4.66 | 138.0 | 5.07 | 153.5 | 5.48 | 169.0 | 5.89 | 184.5 | 6.30 | 200.0 |
| 2.21 | 41.6 | 2.62 | 57.0 | 3.03 | 72.4 | 3.44 | 92.0 | 3.85 | 107.5 | 4.26 | 123.0 | 4.67 | 138.5 | 5.08 | 154.0 | 5.49 | 169.5 | 5.90 | 185.0 | 6.31 | 200.5 |
| 2.22 | 42.0 | 2.63 | 57.4 | 3.04 | 72.7 | 3.45 | 92.5 | 3.86 | 108.0 | 4.27 | 123.5 | 4.68 | 139.0 | 5.09 | 154.5 | 5.50 | 170.0 | 5.91 | 185.5 | 6.32 | 201.0 |
| 2.23 | 42.4 | 2.64 | 57.7 | 3.05 | 73.1 | 3.46 | 93.0 | 3.87 | 108.5 | 4.28 | 124.0 | 4.69 | 139.5 | 5.10 | 155.0 | 5.51 | 170.5 | 5.92 | 186.0 | 6.33 | 201.5 |
| 2.24 | 42.7 | 2.65 | 58.1 | 3.06 | 73.5 | 3.47 | 93.5 | 3.88 | 109.0 | 4.29 | 124.5 | 4.70 | 140.0 | 5.11 | 155.5 | 5.52 | 171.0 | 5.93 | 186.5 | 6.34 | 202.0 |
| 2.25 | 43.1 | 2.66 | 58.5 | 3.07 | 73.9 | 3.48 | 94.0 | 3.89 | 109.5 | 4.30 | 125.0 | 4.71 | 140.5 | 5.12 | 156.0 | 5.53 | 171.5 | 5.94 | 187.0 | 6.35 | 202.5 |
| 2.26 | 43.5 | 2.67 | 58.9 | 3.08 | 74.2 | 3.49 | 94.5 | 3.90 | 110.0 | 4.31 | 125.5 | 4.72 | 141.0 | 5.13 | 156.5 | 5.54 | 172.0 | 5.95 | 187.5 | 6.36 | 203.0 |
| 2.27 | 43.9 | 2.68 | 59.2 | 3.09 | 74.6 | 3.50 | 95.0 | 3.91 | 110.5 | 4.32 | 126.0 | 4.73 | 141.5 | 5.14 | 157.0 | 5.55 | 172.5 | 5.96 | 188.0 | 6.37 | 203.5 |
| 2.28 | 44.2 | 2.69 | 59.6 | 3.10 | 75.0 | 3.51 | 95.5 | 3.92 | 111.0 | 4.33 | 126.5 | 4.74 | 142.0 | 5.15 | 157.5 | 5.56 | 173.0 | 5.97 | 188.5 | 6.38 | 204.0 |
| 2.29 | 44.6 | 2.70 | 60.0 | 3.11 | 75.5 | 3.52 | 96.0 | 3.93 | 111.5 | 4.34 | 127.0 | 4.75 | 142.5 | 5.16 | 158.0 | 5.57 | 173.5 | 5.98 | 189.0 | 6.39 | 204.5 |
| 2.30 | 45.0 | 2.71 | 60.4 | 3.12 | 76.0 | 3.53 | 96.5 | 3.94 | 112.0 | 4.35 | 127.5 | 4.76 | 143.0 | 5.17 | 158.5 | 5.58 | 174.0 | 5.99 | 189.5 | 6.40 | 205.0 |