

2-Hour Fire Rating

6" C.M.U.

Fire Rating: 2 Hour

No. 6-2-910350D2

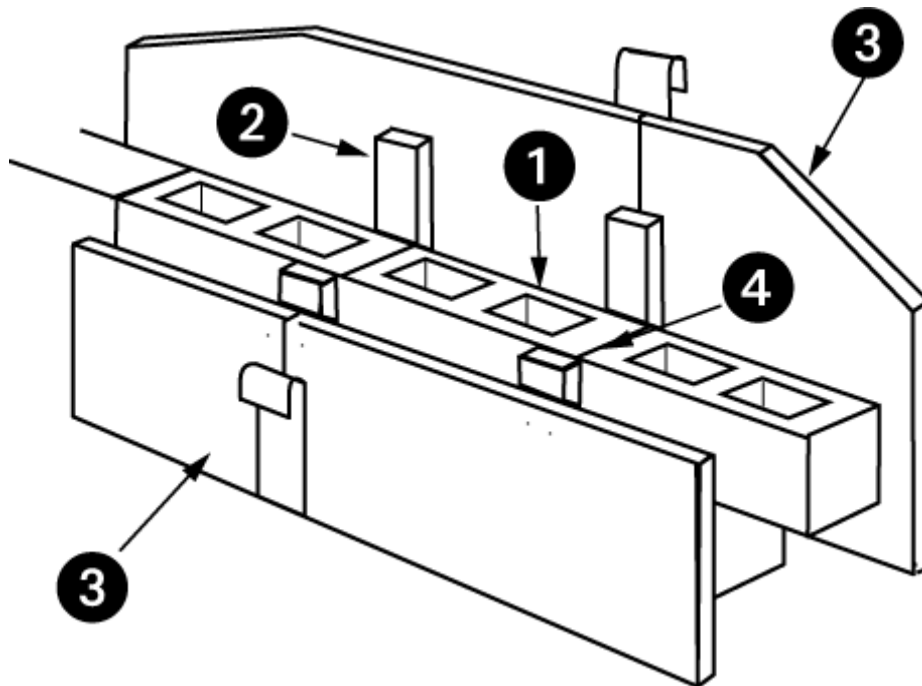

Assembly Information

1. Preferred product 910350 c.m.u. 6" x 8" x 16" nominal
2. Wood or steel furring members - 16" o.c. maximum.
3. Gypsum wallboard, 3/8" thick, both sides, long dimension parallel to furring members - all joints finished
4. ASTM C-270 Masonry Mortar, Type M or S. Face shell or full mortar bedding as required.
5. Masonry grout, reinforcing steel, joint reinforcement, anchors, ties and accessories (Not depicted above - optional). Use where specified.

Preferred Materials Inc. accepts no responsibility for proper application of the rated wall assembly above, or responsibility for the construction of such assemblies.

Fire Rating: 2 Hour No. 6-2-910350D2

Concrete Masonry Unit

Section 3.1 of ACI 216.1

Unit Description	Size WxHxL Nominal	Equivalent Thickness Inches	Fire Rating Minutes
910350	6x8x16	3.2	78.2*

** Linear interpolation from Table 3.1 of ACI 216.1 for Exposed Finish Block Mix – 55% limestone & 45% siliceous aggregates.*

Section 721.3.1.3 and 721.3.1.4 of the Florida Building Code

Solid Grouted construction and/or cells filled with loose-fill materials

Included	Equivalent Thickness Inches	Fire Rating Minutes
No	3.2	78.2*
Yes	N/A	N/A

** Linear interpolation from Table 3.1 of ACI 216.1 for Exposed Finish Block Mix – 55% limestone & 45% siliceous aggregates.*

Fire Rating: 2 Hour

No. 6-2-910350D2

Nonfire-exposed side

Side 1

Section 5.2.2 of ACI 216.1

Finish	
3/8 inch thick Gypsum Wallboard	.375
Multiplying factor Table 5.1	3
Adjusted Thickness	1.12
Concrete Masonry Unit	
Unit Description	910350
Size WxHxL Nominal	6x8x16
Equivalent Thickness	3.2
Fire Rating Minutes	78.2
Total Thickness, CMU + Finish	4.32
Fire Resistance Rating of CMU & Finish, 5.1	133.1*

* Linear interpolation from Table 3.1 of ACI 216.1 for Exposed Finish Block Mix – 55% limestone & 45% siliceous aggregates.

Max. allowable assembly Fire Resistance Block + finishes	117.3
Total Assembly Fire-Resistance Rating	117.3

Side 2

Section 5.2.2 of ACI 216.1

Finish	
3/8 inch thick Gypsum Wallboard	.375
Multiplying factor Table 5.1	3
Adjusted Thickness (inches)	1.12
Concrete Masonry Unit	
Unit Description	910350
Size WxHxL Nominal	6x8x16
Equivalent Thickness (inches)	3.2
Fire Rating Minutes	78.2
Total Thickness, CMU + Finish (inches)	4.32
Fire Resistance Rating of CMU & Finish, Table 5.1	133.1*

** Linear interpolation from Table 3.1 of ACI 216.1 for Exposed Finish Block Mix – 55% limestone & 45% siliceous aggregates.*

Max. allowable assembly Fire Resistance Block + finishes	117.3
Total Assembly Fire-Resistance Rating	117.3

Fire Rating: 2 Hour

No. 6-2-910350D2

Fire-exposed side

Side 1

Section 5.2.3 of ACI 216.1

Finish	
3/8 inch thick Gypsum Wallboard	
Time assigned to finish materials Table 5.2	10
Fire Resistance of CMU and Nonfire-exposed side Finish Table 3.1	117.3
Assembly Fire-Resistance Rating	127.3
Max. allowable assembly Fire Resistance Block + finishes	156.4
Total Assembly Fire-Resistance Rating	127.3

Side 2

Section 5.2.3 of ACI 216.1

Finish	
3/8 inch thick Gypsum Wallboard	
Time assigned to finish materials Table 5.2	10
Fire Resistance of CMU and Nonfire-exposed side Finish Table 3.1	117.3
Assembly Fire-Resistance Rating	127.3
Max. allowable assembly Fire Resistance Block + finishes	156.4
Total Assembly Fire-Resistance Rating	127.3

Assembly Fire-Resistance Rating	127.3 Minutes
--	----------------------

Fire Resistance Rating, minutes per inches of equivalent thickness
Linear Interpolation from Table 3.1 of ACI 216.1
Exposed Finish Mix - 55% limestone + 45% siliceous aggregates

et	min	et	min	et	min	et	min	et	min	et	min	et	min	et	min	et	min
2.75	60.0	3.16	76.6	3.57	94.0	3.98	114.5	4.39	137.1	4.80	160.5	5.21	184.7	5.62	212.0	6.03	239.4
2.76	60.4	3.17	77.0	3.58	94.5	3.99	115.0	4.40	137.7	4.81	161.1	5.22	185.3	5.63	212.7	6.04	240.0
2.77	60.8	3.18	77.4	3.59	95.0	4.00	115.5	4.41	138.3	4.82	161.7	5.23	186.0	5.64	213.3		
2.78	61.2	3.19	77.8	3.60	95.5	4.01	116.0	4.42	138.8	4.83	162.3	5.24	186.7	5.65	214.0		
2.79	61.6	3.20	78.2	3.61	96.0	4.02	116.5	4.43	139.4	4.84	162.8	5.25	187.3	5.66	214.7		
2.80	62.0	3.21	78.6	3.62	96.5	4.03	117.0	4.44	140.0	4.85	163.4	5.26	188.0	5.67	215.4		
2.81	62.4	3.22	79.0	3.63	97.0	4.04	117.5	4.45	140.6	4.86	164.0	5.27	188.7	5.68	216.0		
2.82	62.8	3.23	79.4	3.64	97.5	4.05	118.0	4.46	141.1	4.87	164.5	5.28	189.3	5.69	216.7		
2.83	63.2	3.24	79.8	3.65	98.0	4.06	118.5	4.47	141.7	4.88	165.1	5.29	190.0	5.70	217.4		
2.84	63.6	3.25	80.2	3.66	98.5	4.07	119.0	4.48	142.3	4.89	165.7	5.30	190.7	5.71	218.0		
2.85	64.0	3.26	80.7	3.67	99.0	4.08	119.5	4.49	142.8	4.90	166.3	5.31	191.3	5.72	218.7		
2.86	64.5	3.27	81.1	3.68	99.5	4.09	120.0	4.50	143.4	4.91	166.8	5.32	192.0	5.73	219.4		
2.87	64.9	3.28	81.5	3.69	100.0	4.10	120.6	4.51	144.0	4.92	167.4	5.33	192.7	5.74	220.0		
2.88	65.3	3.29	81.9	3.70	100.5	4.11	121.1	4.52	144.6	4.93	168.0	5.34	193.3	5.75	220.7		
2.89	65.7	3.30	82.3	3.71	101.0	4.12	121.7	4.53	145.1	4.94	168.5	5.35	194.0	5.76	221.4		
2.90	66.1	3.31	82.7	3.72	101.5	4.13	122.3	4.54	145.7	4.95	169.1	5.36	194.7	5.77	222.0		
2.91	66.5	3.32	83.1	3.73	102.0	4.14	122.9	4.55	146.3	4.96	169.7	5.37	195.3	5.78	222.7		
2.92	66.9	3.33	83.5	3.74	102.5	4.15	123.4	4.56	146.8	4.97	170.2	5.38	196.0	5.79	223.4		
2.93	67.3	3.34	83.9	3.75	103.0	4.16	124.0	4.57	147.4	4.98	170.8	5.39	196.7	5.80	224.0		
2.94	67.7	3.35	84.3	3.76	103.5	4.17	124.6	4.58	148.0	4.99	171.4	5.40	197.3	5.81	224.7		
2.95	68.1	3.36	84.7	3.77	104.0	4.18	125.1	4.59	148.5	5.00	172.0	5.41	198.0	5.82	225.4		
2.96	68.5	3.37	85.1	3.78	104.5	4.19	125.7	4.60	149.1	5.01	172.5	5.42	198.7	5.83	226.0		
2.97	68.9	3.38	85.5	3.79	105.0	4.20	126.3	4.61	149.7	5.02	173.1	5.43	199.3	5.84	226.7		
2.98	69.3	3.39	85.9	3.80	105.5	4.21	126.9	4.62	150.3	5.03	173.7	5.44	200.0	5.85	227.4		
2.99	69.7	3.40	86.3	3.81	106.0	4.22	127.4	4.63	150.8	5.04	174.2	5.45	200.7	5.86	228.0		
3.00	70.1	3.41	86.7	3.82	106.5	4.23	128.0	4.64	151.4	5.05	174.8	5.46	201.3	5.87	228.7		
3.01	70.5	3.42	87.1	3.83	107.0	4.24	128.6	4.65	152.0	5.06	175.4	5.47	202.0	5.88	229.4		
3.02	70.9	3.43	87.5	3.84	107.5	4.25	129.1	4.66	152.5	5.07	176.0	5.48	202.7	5.89	230.0		
3.03	71.3	3.44	87.9	3.85	108.0	4.26	129.7	4.67	153.1	5.08	176.5	5.49	203.3	5.90	230.7		
3.04	71.7	3.45	88.3	3.86	108.5	4.27	130.3	4.68	153.7	5.09	177.1	5.50	204.0	5.91	231.4		
3.05	72.1	3.46	88.8	3.87	109.0	4.28	130.8	4.69	154.3	5.10	177.7	5.51	204.7	5.92	232.0		
3.06	72.6	3.47	89.2	3.88	109.5	4.29	131.4	4.70	154.8	5.11	178.2	5.52	205.3	5.93	232.7		
3.07	73.0	3.48	89.6	3.89	110.0	4.30	132.0	4.71	155.4	5.12	178.8	5.53	206.0	5.94	233.4		
3.08	73.4	3.49	90.0	3.90	110.5	4.31	132.6	4.72	156.0	5.13	179.4	5.54	206.7	5.95	234.0		
3.09	73.8	3.50	90.5	3.91	111.0	4.32	133.1	4.73	156.5	5.14	180.0	5.55	207.3	5.96	234.7		
3.10	74.2	3.51	91.0	3.92	111.5	4.33	133.7	4.74	157.1	5.15	180.7	5.56	208.0	5.97	235.4		
3.11	74.6	3.52	91.5	3.93	112.0	4.34	134.3	4.75	157.7	5.16	181.3	5.57	208.7	5.98	236.0		
3.12	75.0	3.53	92.0	3.94	112.5	4.35	134.8	4.76	158.3	5.17	182.0	5.58	209.3	5.99	236.7		
3.13	75.4	3.54	92.5	3.95	113.0	4.36	135.4	4.77	158.8	5.18	182.7	5.59	210.0	6.00	237.4		
3.14	75.8	3.55	93.0	3.96	113.5	4.37	136.0	4.78	159.4	5.19	183.3	5.60	210.7	6.01	238.0		
3.15	76.2	3.56	93.5	3.97	114.0	4.38	136.6	4.79	160.0	5.20	184.0	5.61	211.3	6.02	238.7		