

## 1.5-Hour Fire Rating

6" C.M.U.

Fire Rating: 1.5 Hour      No. 6-1.5-910350S

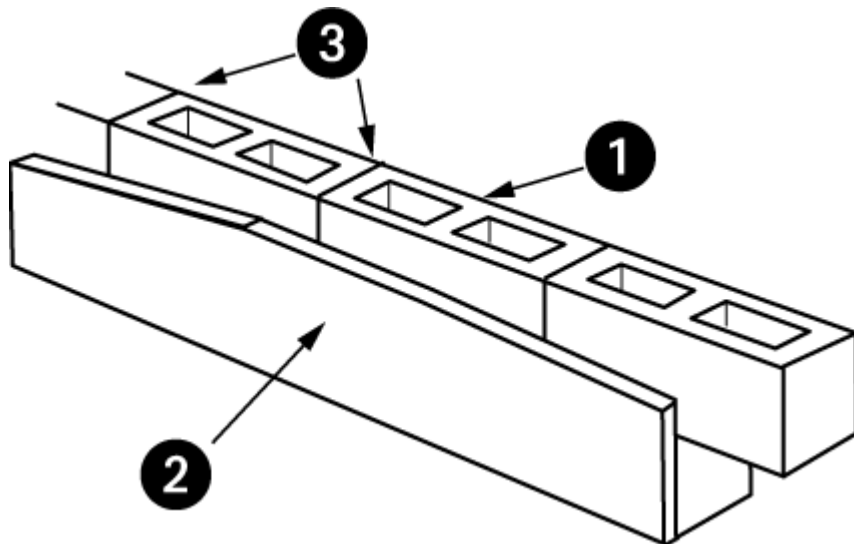

### Assembly Information

1. Preferred product 910350 c.m.u. 6" x 8" x 16" nominal
2. Portland cement stucco - 1/2" thick applied directly to C.M.U.
3. ASTM C-270 Masonry Mortar, Type M, S, or N. Face shell or full mortar bedding as required. Use Type N only in interior, non-load bearing partition walls.
4. Masonry grout, reinforcing steel, joint reinforcement, anchors, ties and accessories (Not depicted above - optional). Use where specified.

***Preferred Materials Inc. accepts no responsibility for proper application of the rated wall assembly above, or responsibility for the construction of such assemblies.***

**Fire Rating: 1.5 Hour    No. 6-1.5-910350S**

## **Concrete Masonry Unit**

**Section 721.3.2 of the Florida Building Code**

<b>Unit Description</b>	<b>Size WxHxL Nominal</b>	<b>Equivalent Thickness Inches</b>	<b>Fire Rating Minutes</b>
<b>910350</b>	<b>6x8x16</b>	<b>3.2</b>	<b>77.2*</b>

*\* Linear interpolation from Table 721.3.2 of the Florida Building Code for Exposed Finish Block Mix – 55% limestone & 45% siliceous aggregates.*

**Section 721.3.1.3 and 721.3.1.4 of the Florida Building Code**

**Solid Grouted construction and/or cells filled with loose-fill materials**

<b>Included</b>	<b>Equivalent Thickness Inches</b>	<b>Fire Rating Minutes</b>
<b>No</b>	<b>3.2</b>	<b>77.2*</b>
<b>Yes</b>	<b>N/A</b>	<b>N/A</b>

*\* Linear interpolation from Table 721.3.2 of the Florida Building Code for Exposed Finish Block Mix – 55% limestone & 45% siliceous aggregates.*

# Fire Rating: 1.5 Hour No. 6-1.5-910350S

## Nonfire-exposed side

### Side 1

#### Section 721.3.2.1 of the Florida Building Code

Finish	
½ inch thick Portland cement-sand Stucco	.5
Multiplying factor Table 721.2.1.4(1)	1
Adjusted Thickness	.5
Concrete Masonry Unit	
Unit Description	910350
Size WxHxL Nominal	6x8x16
Equivalent Thickness	3.2
Fire Rating Minutes	77.2
Total Thickness, CMU + Finish	3.7
Fire Resistance Rating of CMU & Finish, Table 721.3.2	100.5*

\* Linear interpolation from Table 721.3.2 of the Florida Building Code for Exposed Finish Block Mix – 55% limestone & 45% siliceous aggregates.

### Side 2

#### Section 721.3.2.1 of the Florida Building Code

Finish	
None	0
Multiplying factor Table 721.2.1.4(1)	NA
Adjusted Thickness (inches)	0
Concrete Masonry Unit	
Unit Description	910350
Size WxHxL Nominal	6x8x16
Equivalent Thickness (inches)	3.2
Fire Rating Minutes	77.2
Total Thickness, CMU + Finish (inches)	3.2
Fire Resistance Rating of CMU & Finish, Table 721.3.2	77.2*

\* Linear interpolation from Table 721.3.2 of the Florida Building Code for Exposed Finish Block Mix – 55% limestone & 45% siliceous aggregates.

**Fire Rating: 1.5 Hour No. 6-1.5-910350S**

**Fire-exposed side**

**Side 1**

**Section 721.3.2.2 of the Florida Building Code**

<b>Finish</b>	
<b>None</b>	
<b>Time assigned to finish materials Table 721.2.1.4(2)</b>	<b>0</b>
<b>Fire Resistance of CMU and Nonfire-exposed side Finish Table 721.3.2</b>	<b>100.5</b>
<b>Assembly Fire-Resistance Rating</b>	<b>100.5</b>
<b>Max. allowable assembly Fire Resistance Block + finishes</b>	<b>154.4</b>
<b>Total Assembly Fire-Resistance Rating</b>	<b>100.5</b>

**Side 2**

**Section 721.3.2.2 of the Florida Building Code**

<b>Finish</b>	
<b>½ inch thick Portland cement-sand Stucco</b>	
<b>Time assigned to finish materials Table 721.2.1.4(2)</b>	<b>0 0.5</b>
<b>Fire Resistance of CMU and Nonfire-exposed side Finish Table 721.3.2</b>	<b>0 3.2</b>
<b>Assembly Fire-Resistance Rating</b>	<b>100.5 3.7</b>
<b>Max. allowable assembly Fire Resistance Block + finishes</b>	<b>154.4</b>
<b>Total Assembly Fire-Resistance Rating</b>	<b>100.5</b>

<b>Assembly Fire-Resistance Rating</b>	<b>100.5 Minutes</b>
--	----------------------

**Fire Resistance Rating, minutes per inches of equivalent thickness  
Linear Interpolation from table 721.3.2 of the 2007 Florida Building Code  
Exposed Finish Block Mix – 55% Limestone & 45% Siliceous Aggregates**

1.95	30.0	2.36	45.4	2.77	60.8	3.18	76.3	3.59	95.0	4.00	115.5	4.41	136.2	4.82	160.8	5.23	186.8	5.64	210.0
1.96	30.4	2.37	45.8	2.78	61.1	3.19	76.8	3.60	95.5	4.01	116.0	4.42	136.8	4.83	161.4	5.24	187.5	5.65	210.8
1.97	30.8	2.38	46.1	2.79	61.5	3.20	77.2	3.61	96.0	4.02	116.5	4.43	137.4	4.84	162.0	5.25	188.3	5.66	211.5
1.98	31.1	2.39	46.5	2.80	61.9	3.21	77.6	3.62	96.5	4.03	117.0	4.44	138.0	4.85	162.6	5.26	189.0	5.67	212.3
1.99	31.5	2.40	46.9	2.81	62.3	3.22	78.1	3.63	97.0	4.04	117.5	4.45	138.6	4.86	163.2	5.27	189.8	5.68	213.0
2.00	31.9	2.41	47.3	2.82	62.6	3.23	78.5	3.64	97.5	4.05	118.0	4.46	139.2	4.87	163.8	5.28	190.5	5.69	213.8
2.01	32.3	2.42	47.6	2.83	63.0	3.24	79.0	3.65	98.0	4.06	118.5	4.47	139.8	4.88	164.4	5.29	191.3	5.70	214.5
2.02	32.6	2.43	48.0	2.84	63.4	3.25	79.4	3.66	98.5	4.07	119.0	4.48	140.4	4.89	165.0	5.30	192.0	5.71	215.3
2.03	33.0	2.44	48.4	2.85	63.7	3.26	79.9	3.67	99.0	4.08	119.5	4.49	141.0	4.90	165.6	5.31	192.8	5.72	216.0
2.04	33.4	2.45	48.7	2.86	64.1	3.27	80.3	3.68	99.5	4.09	120.0	4.50	141.6	4.91	166.2	5.32	193.5	5.73	216.8
2.05	33.8	2.46	49.1	2.87	64.5	3.28	80.7	3.69	100.0	4.10	120.5	4.51	142.2	4.92	166.8	5.33	194.3	5.74	217.5
2.06	34.1	2.47	49.5	2.88	64.9	3.29	81.2	3.70	100.5	4.11	121.0	4.52	142.8	4.93	167.4	5.34	195.0	5.75	218.3
2.07	34.5	2.48	49.9	2.89	65.2	3.30	81.6	3.71	101.0	4.12	121.5	4.53	143.4	4.94	168.0	5.35	195.5	5.76	219.0
2.08	34.9	2.49	50.2	2.90	65.6	3.31	82.1	3.72	101.5	4.13	122.0	4.54	144.0	4.95	168.6	5.36	196.0	5.77	219.8
2.09	35.2	2.50	50.6	2.91	66.0	3.32	82.5	3.73	102.0	4.14	122.5	4.55	144.6	4.96	169.2	5.37	196.5	5.78	220.5
2.10	35.6	2.51	51.0	2.92	66.4	3.33	82.9	3.74	102.5	4.15	123.0	4.56	145.2	4.97	169.8	5.38	197.0	5.79	221.3
2.11	36.0	2.52	51.4	2.93	66.7	3.34	83.4	3.75	103.0	4.16	123.5	4.57	145.8	4.98	170.4	5.39	197.5	5.80	222.0
2.12	36.4	2.53	51.7	2.94	67.1	3.35	83.8	3.76	103.5	4.17	124.0	4.58	146.4	4.99	171.0	5.40	198.0	5.81	222.8
2.13	36.7	2.54	52.1	2.95	67.5	3.36	84.3	3.77	104.0	4.18	124.5	4.59	147.0	5.00	171.6	5.41	198.5	5.82	223.5
2.14	37.1	2.55	52.5	2.96	67.9	3.37	84.7	3.78	104.5	4.19	125.0	4.60	147.6	5.01	172.2	5.42	199.0	5.83	224.3
2.15	37.5	2.56	52.9	2.97	68.2	3.38	85.1	3.79	105.0	4.20	125.5	4.61	148.2	5.02	172.8	5.43	199.5	5.84	225.0
2.16	37.9	2.57	53.2	2.98	68.6	3.39	85.6	3.80	105.5	4.21	126.0	4.62	148.8	5.03	173.4	5.44	200.0	5.85	225.8
2.17	38.2	2.58	53.6	2.99	69.0	3.40	86.0	3.81	106.0	4.22	126.5	4.63	149.4	5.04	174.0	5.45	200.5	5.86	226.5
2.18	38.6	2.59	54.0	3.00	69.4	3.41	86.5	3.82	106.5	4.23	127.0	4.64	150.0	5.05	174.6	5.46	201.0	5.87	227.3
2.19	39.0	2.60	54.4	3.01	69.7	3.42	86.9	3.83	107.0	4.24	127.5	4.65	150.6	5.06	175.2	5.47	201.5	5.88	228.0
2.20	39.4	2.61	54.7	3.02	70.1	3.43	87.3	3.84	107.5	4.25	128.0	4.66	151.2	5.07	175.8	5.48	202.0	5.89	228.8
2.21	39.7	2.62	55.1	3.03	70.5	3.44	87.8	3.85	108.0	4.26	128.5	4.67	151.8	5.08	176.4	5.49	202.5	5.90	229.5
2.22	40.1	2.63	55.5	3.04	70.9	3.45	88.2	3.86	108.5	4.27	129.0	4.68	152.4	5.09	177.0	5.50	203.0	5.91	230.3
2.23	40.5	2.64	55.9	3.05	71.2	3.46	88.7	3.87	109.0	4.28	129.5	4.69	153.0	5.10	177.6	5.51	203.5	5.92	231.0
2.24	40.9	2.65	56.2	3.06	71.6	3.47	89.1	3.88	109.5	4.29	130.0	4.70	153.6	5.11	178.2	5.52	204.0	5.93	231.8
2.25	41.2	2.66	56.6	3.07	72.0	3.48	89.6	3.89	110.0	4.30	130.5	4.71	154.2	5.12	178.8	5.53	204.5	5.94	232.5
2.26	41.6	2.67	57.0	3.08	72.4	3.49	90.0	3.90	110.5	4.31	131.0	4.72	154.8	5.13	179.4	5.54	205.0	5.95	233.3
2.27	42.0	2.68	57.4	3.09	72.7	3.50	90.5	3.91	111.0	4.32	131.5	4.73	155.4	5.14	180.0	5.55	205.5	5.96	234.0
2.28	42.4	2.69	57.7	3.10	73.1	3.51	91.0	3.92	111.5	4.33	132.0	4.74	156.0	5.15	180.8	5.56	206.0	5.97	234.8
2.29	42.7	2.70	58.1	3.11	73.5	3.52	91.5	3.93	112.0	4.34	132.5	4.75	156.6	5.16	181.5	5.57	206.5	5.98	235.5
2.30	43.1	2.71	58.5	3.12	73.9	3.53	92.0	3.94	112.5	4.35	133.0	4.76	157.2	5.17	182.3	5.58	207.0	5.99	236.3
2.31	43.5	2.72	58.9	3.13	74.2	3.54	92.5	3.95	113.0	4.36	133.5	4.77	157.8	5.18	183.0	5.59	207.5	6.00	237.0
2.32	43.9	2.73	59.2	3.14	74.6	3.55	93.0	3.96	113.5	4.37	134.0	4.78	158.4	5.19	183.8	5.60	208.0	6.01	237.8
2.33	44.2	2.74	59.6	3.15	75.0	3.56	93.5	3.97	114.0	4.38	134.5	4.79	159.0	5.20	184.5	5.61	208.5	6.02	238.5
2.34	44.6	2.75	60.0	3.16	75.4	3.57	94.0	3.98	114.5	4.39	135.0	4.80	159.6	5.21	185.3	5.62	209.0	6.03	239.3
2.35	45.0	2.76	60.4	3.17	75.9	3.58	94.5	3.99	115.0	4.40	135.6	4.81	160.2	5.22	186.0	5.63	209.5	6.04	240.0

**Fire Resistance Rating, minutes per inches of equivalent thickness  
Direct Interpolation from table 721.3.2 of the 2007 Florida Building Code  
Stucco/Sand Finish Block Mix – 100% Limestone**

1.90	30.0	2.31	45.4	2.72	60.8	3.13	76.5	3.54	97.0	3.95	117.5	4.36	139.5	4.77	163.5	5.18	193.5	5.59	216.8
1.91	30.4	2.32	45.8	2.73	61.1	3.14	77.0	3.55	97.5	3.96	118.0	4.37	140.3	4.78	164.0	5.19	194.3	5.60	217.5
1.92	30.8	2.33	46.1	2.74	61.5	3.15	77.5	3.56	98.0	3.97	118.5	4.38	141.0	4.79	164.5	5.20	195.0	5.61	218.3
1.93	31.1	2.34	46.5	2.75	61.9	3.16	78.0	3.57	98.5	3.98	119.0	4.39	141.8	4.80	165.0	5.21	195.5	5.62	219.0
1.94	31.5	2.35	46.9	2.76	62.3	3.17	78.5	3.58	99.0	3.99	119.5	4.40	142.5	4.81	165.8	5.22	196.0	5.63	219.8
1.95	31.9	2.36	47.3	2.77	62.6	3.18	79.0	3.59	99.5	4.00	120.0	4.41	143.3	4.82	166.5	5.23	196.5	5.64	220.5
1.96	32.3	2.37	47.6	2.78	63.0	3.19	79.5	3.60	100.0	4.01	120.5	4.42	144.0	4.83	167.3	5.24	197.0	5.65	221.3
1.97	32.6	2.38	48.0	2.79	63.4	3.20	80.0	3.61	100.5	4.02	121.0	4.43	144.8	4.84	168.0	5.25	197.5	5.66	222.0
1.98	33.0	2.39	48.4	2.80	63.7	3.21	80.5	3.62	101.0	4.03	121.5	4.44	145.5	4.85	168.8	5.26	198.0	5.67	222.8
1.99	33.4	2.40	48.8	2.81	64.1	3.22	81.0	3.63	101.5	4.04	122.0	4.45	146.3	4.86	169.5	5.27	198.5	5.68	223.5
2.00	33.8	2.41	49.1	2.82	64.5	3.23	81.5	3.64	102.0	4.05	122.5	4.46	147.0	4.87	170.3	5.28	199.0	5.69	224.3
2.01	34.1	2.42	49.5	2.83	64.9	3.24	82.0	3.65	102.5	4.06	123.0	4.47	147.8	4.88	171.0	5.29	199.5	5.70	225.0
2.02	34.5	2.43	49.9	2.84	65.2	3.25	82.5	3.66	103.0	4.07	123.5	4.48	148.5	4.89	171.8	5.30	200.0	5.71	225.8
2.03	34.9	2.44	50.3	2.85	65.6	3.26	83.0	3.67	103.5	4.08	124.0	4.49	149.3	4.90	172.5	5.31	200.5	5.72	226.5
2.04	35.3	2.45	50.6	2.86	66.0	3.27	83.5	3.68	104.0	4.09	124.5	4.50	150.0	4.91	173.3	5.32	201.0	5.73	227.3
2.05	35.6	2.46	51.0	2.87	66.4	3.28	84.0	3.69	104.5	4.10	125.0	4.51	150.5	4.92	174.0	5.33	201.5	5.74	228.0
2.06	36.0	2.47	51.4	2.88	66.7	3.29	84.5	3.70	105.0	4.11	125.5	4.52	151.0	4.93	174.8	5.34	202.0	5.75	228.8
2.07	36.4	2.48	51.7	2.89	67.1	3.30	85.0	3.71	105.5	4.12	126.0	4.53	151.5	4.94	175.5	5.35	202.5	5.76	229.5
2.08	36.7	2.49	52.1	2.90	67.5	3.31	85.5	3.72	106.0	4.13	126.5	4.54	152.0	4.95	176.3	5.36	203.0	5.77	230.3
2.09	37.1	2.50	52.5	2.91	67.9	3.32	86.0	3.73	106.5	4.14	127.0	4.55	152.5	4.96	177.0	5.37	203.5	5.78	231.0
2.10	37.5	2.51	52.9	2.92	68.2	3.33	86.5	3.74	107.0	4.15	127.5	4.56	153.0	4.97	177.8	5.38	204.0	5.79	231.8
2.11	37.9	2.52	53.2	2.93	68.6	3.34	87.0	3.75	107.5	4.16	128.0	4.57	153.5	4.98	178.5	5.39	204.5	5.80	232.5
2.12	38.2	2.53	53.6	2.94	69.0	3.35	87.5	3.76	108.0	4.17	128.5	4.58	154.0	4.99	179.3	5.40	205.0	5.81	233.3
2.13	38.6	2.54	54.0	2.95	69.4	3.36	88.0	3.77	108.5	4.18	129.0	4.59	154.5	5.00	180.0	5.41	205.5	5.82	234.0
2.14	39.0	2.55	54.4	2.96	69.7	3.37	88.5	3.78	109.0	4.19	129.5	4.60	155.0	5.01	180.8	5.42	206.0	5.83	234.8
2.15	39.4	2.56	54.7	2.97	70.1	3.38	89.0	3.79	109.5	4.20	130.0	4.61	155.5	5.02	181.5	5.43	206.5	5.84	235.5
2.16	39.7	2.57	55.1	2.98	70.5	3.39	89.5	3.80	110.0	4.21	130.5	4.62	156.0	5.03	182.3	5.44	207.0	5.85	236.3
2.17	40.1	2.58	55.5	2.99	70.9	3.40	90.0	3.81	110.5	4.22	131.0	4.63	156.5	5.04	183.0	5.45	207.5	5.86	237.0
2.18	40.5	2.59	55.9	3.00	71.2	3.41	90.5	3.82	111.0	4.23	131.5	4.64	157.0	5.05	183.8	5.46	208.0	5.87	237.8
2.19	40.9	2.60	56.2	3.01	71.6	3.42	91.0	3.83	111.5	4.24	132.0	4.65	157.5	5.06	184.5	5.47	208.5	5.88	238.5
2.20	41.2	2.61	56.6	3.02	72.0	3.43	91.5	3.84	112.0	4.25	132.5	4.66	158.0	5.07	185.3	5.48	209.0	5.89	239.3
2.21	41.6	2.62	57.0	3.03	72.4	3.44	92.0	3.85	112.5	4.26	133.0	4.67	158.5	5.08	186.0	5.49	209.5	5.90	240.0
2.22	42.0	2.63	57.4	3.04	72.7	3.45	92.5	3.86	113.0	4.27	133.5	4.68	159.0	5.09	186.8	5.50	210.0		
2.23	42.4	2.64	57.7	3.05	73.1	3.46	93.0	3.87	113.5	4.28	134.0	4.69	159.5	5.10	187.5	5.51	210.8		
2.24	42.7	2.65	58.1	3.06	73.5	3.47	93.5	3.88	114.0	4.29	134.5	4.70	160.0	5.11	188.3	5.52	211.5		
2.25	43.1	2.66	58.5	3.07	73.9	3.48	94.0	3.89	114.5	4.30	135.0	4.71	160.5	5.12	189.0	5.53	212.3		
2.26	43.5	2.67	58.9	3.08	74.2	3.49	94.5	3.90	115.0	4.31	135.8	4.72	161.0	5.13	189.8	5.54	213.0		
2.27	43.9	2.68	59.2	3.09	74.6	3.50	95.0	3.91	115.5	4.32	136.5	4.73	161.5	5.14	190.5	5.55	213.8		
2.28	44.2	2.69	59.6	3.10	75.0	3.51	95.5	3.92	116.0	4.33	137.3	4.74	162.0	5.15	191.3	5.56	214.5		
2.29	44.6	2.70	60.0	3.11	75.5	3.52	96.0	3.93	116.5	4.34	138.0	4.75	162.5	5.16	192.0	5.57	215.3		
2.30	45.0	2.71	60.4	3.12	76.0	3.53	96.5	3.94	117.0	4.35	138.8	4.76	163.0	5.17	192.8	5.58	216.0		