

## 2-Hour Fire Rating

4" C.M.U.

Fire Rating: 2 Hour

No. 4-2-910275GFS

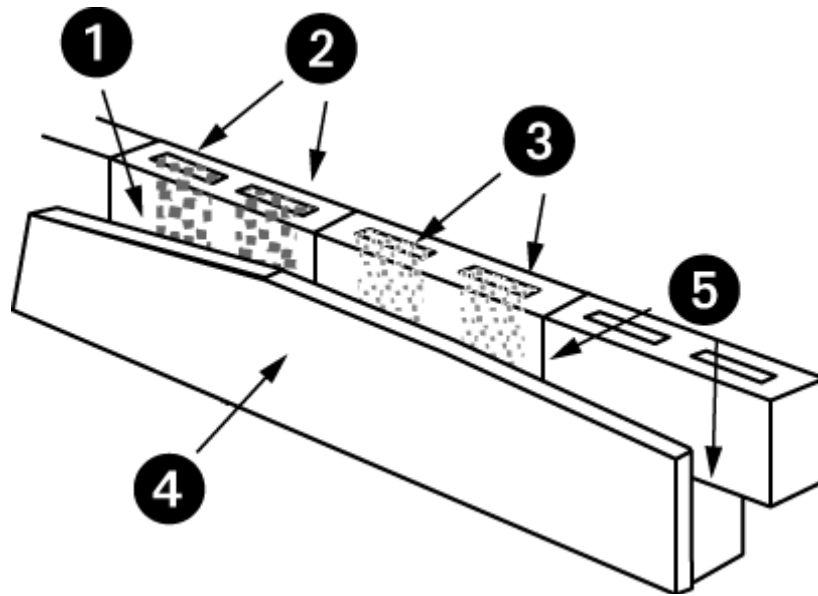

### Assembly Information

1. Preferred Product 910275 c.m.u. 4" x 8" x 16" nominal.

2. Masonry grout - all cells filled

**OR**

3. Approved loose fill material - all cells filled\*

4. Portland cement stucco - 1/2" thick applied directly to C.M.U.

5. ASTM C270 Masonry Mortar, Type M or S. Face shell or full mortar bedding as required.

6. Masonry grout, reinforcing steel, joint reinforcement, anchors, ties and accessories (Not depicted above – optional). Use where specified.

\*Approved loose fill materials include: sand, pea gravel, crushed stone or slag that meet ASTM C33 requirements; pumice, scoria, expanded shale, expanded clay, expanded slate, expanded slag, expanded fly ash, or cinders in compliance with ASTM C331; perlite or vermiculite that complies with ASTM C332 or ASTM C549 and C516, respectively.

***Preferred Materials Inc. accepts no responsibility for proper application of the rated wall assembly above, or responsibility for the construction of such assemblies.***

**Fire Rating: 2 Hour      No. 4-2-910275GFS**

## **Concrete Masonry Unit**

**Section 721.3.2 of the Florida Building Code**

<b>Unit Description</b>	<b>Size WxHxL Nominal</b>	<b>Equivalent Thickness Inches</b>	<b>Fire Rating Minutes</b>
<b>910275</b>	<b>4x8x16</b>	<b>2.9</b>	<b>65.6*</b>

*\* Linear interpolation from Table 721.3.2 of the Florida Building Code for Exposed Finish Block Mix – 55% limestone & 45% siliceous aggregates.*

**Section 721.3.1.3 and 721.3.1.4 of the Florida Building Code**

**Solid Grouted construction and/or cells filled with loose-fill materials**

<b>Included</b>	<b>Equivalent Thickness Inches</b>	<b>Fire Rating Minutes</b>
<b>No</b>	<b>N/A</b>	<b>N/A</b>
<b>Yes</b>	<b>3.62</b>	<b>96.5*</b>

*\* Linear interpolation from Table 721.3.2 of the Florida Building Code for Exposed Finish Block Mix – 55% limestone & 45% siliceous aggregates.*

**Fire Rating: 2 Hour**

**No. 4-2-910275GFS**

**Nonfire-exposed side**

**Side 1**

**Section 721.3.2.1 of the Florida Building Code**

<b>Finish</b>	
½ inch thick Portland cement-sand Stucco	<b>0.5</b>
Multiplying factor Table 721.2.1.4(1)	<b>1</b>
Adjusted Thickness	<b>.5</b>
<b>Concrete Masonry Unit</b>	
Unit Description	<b>910275</b>
Size WxHxL Nominal	<b>4x8x16</b>
Equivalent Thickness	<b>3.62</b>
Fire Rating Minutes	<b>96.5</b>
Total Thickness, CMU + Finish	<b>4.12</b>
Fire Resistance Rating of CMU & Finish, Table 721.3.2	<b>121.5*</b>

*\* Linear interpolation from Table 721.3.2 of the Florida Building Code for Exposed Finish Block Mix – 55% limestone & 45% siliceous aggregates.*

**Side 2**

**Section 721.3.2.1 of the Florida Building Code**

<b>Finish</b>	
None	<b>0</b>
Multiplying factor Table 721.2.1.4(1)	<b>N/A</b>
Adjusted Thickness (inches)	<b>0</b>
<b>Concrete Masonry Unit</b>	
Unit Description	<b>910275</b>
Size WxHxL Nominal	<b>4x8x16</b>
Equivalent Thickness (inches)	<b>3.62</b>
Fire Rating Minutes	<b>96.5</b>
Total Thickness, CMU + Finish (inches)	<b>3.62</b>
Fire Resistance Rating of CMU & Finish, Table 721.3.2	<b>96.5*</b>

*\* Linear interpolation from Table 721.3.2 of the Florida Building Code for Exposed Finish Block Mix – 55% limestone & 45% siliceous aggregates.*

**Fire Rating: 2 Hour      No. 4-2-910275GFS**

**Fire-exposed side**

**Side 1**

**Section 721.3.2.2 of the Florida Building Code**

<b>Finish</b>	
None	0
Time assigned to finish materials Table 721.2.1.4(2)	0
Fire Resistance of CMU and Nonfire-exposed side Finish Table 721.3.2	121.5
Assembly Fire-Resistance Rating	121.5
Max. allowable assembly Fire Resistance Block + finishes	131.2
Total Assembly Fire-Resistance Rating	121.5

**Side 2**

**Section 721.3.2.2 of the Florida Building Code**

<b>Finish</b>	
½ inch thick Portland cement-sand Stucco	0
Time assigned to finish materials Table 721.2.1.4(2)	0.5
Fire Resistance of CMU and Nonfire-exposed side Finish Table 721.3.2	3.62
Assembly Fire-Resistance Rating	4.12
Max. allowable assembly Fire Resistance Block + finishes	131.2
Total Assembly Fire-Resistance Rating	121.5

<b>Assembly Fire-Resistance Rating</b>	<b>121.5 Minutes</b>
--	----------------------

**Fire Resistance Rating, minutes per inches of equivalent thickness  
Linear Interpolation from table 721.3.2 of the 2007 Florida Building Code  
Exposed Finish Block Mix – 55% Limestone & 45% Siliceous Aggregates**

1.95	30.0	2.36	45.4	2.77	60.8	3.18	76.3	3.59	95.0	4.00	115.5	4.41	136.2	4.82	160.8	5.23	186.8	5.64	210.0
1.96	30.4	2.37	45.8	2.78	61.1	3.19	76.8	3.60	95.5	4.01	116.0	4.42	136.8	4.83	161.4	5.24	187.5	5.65	210.8
1.97	30.8	2.38	46.1	2.79	61.5	3.20	77.2	3.61	96.0	4.02	116.5	4.43	137.4	4.84	162.0	5.25	188.3	5.66	211.5
1.98	31.1	2.39	46.5	2.80	61.9	3.21	77.6	3.62	96.5	4.03	117.0	4.44	138.0	4.85	162.6	5.26	189.0	5.67	212.3
1.99	31.5	2.40	46.9	2.81	62.3	3.22	78.1	3.63	97.0	4.04	117.5	4.45	138.6	4.86	163.2	5.27	189.8	5.68	213.0
2.00	31.9	2.41	47.3	2.82	62.6	3.23	78.5	3.64	97.5	4.05	118.0	4.46	139.2	4.87	163.8	5.28	190.5	5.69	213.8
2.01	32.3	2.42	47.6	2.83	63.0	3.24	79.0	3.65	98.0	4.06	118.5	4.47	139.8	4.88	164.4	5.29	191.3	5.70	214.5
2.02	32.6	2.43	48.0	2.84	63.4	3.25	79.4	3.66	98.5	4.07	119.0	4.48	140.4	4.89	165.0	5.30	192.0	5.71	215.3
2.03	33.0	2.44	48.4	2.85	63.7	3.26	79.9	3.67	99.0	4.08	119.5	4.49	141.0	4.90	165.6	5.31	192.8	5.72	216.0
2.04	33.4	2.45	48.7	2.86	64.1	3.27	80.3	3.68	99.5	4.09	120.0	4.50	141.6	4.91	166.2	5.32	193.5	5.73	216.8
2.05	33.8	2.46	49.1	2.87	64.5	3.28	80.7	3.69	100.0	4.10	120.5	4.51	142.2	4.92	166.8	5.33	194.3	5.74	217.5
2.06	34.1	2.47	49.5	2.88	64.9	3.29	81.2	3.70	100.5	4.11	121.0	4.52	142.8	4.93	167.4	5.34	195.0	5.75	218.3
2.07	34.5	2.48	49.9	2.89	65.2	3.30	81.6	3.71	101.0	4.12	121.5	4.53	143.4	4.94	168.0	5.35	195.5	5.76	219.0
2.08	34.9	2.49	50.2	2.90	65.6	3.31	82.1	3.72	101.5	4.13	122.0	4.54	144.0	4.95	168.6	5.36	196.0	5.77	219.8
2.09	35.2	2.50	50.6	2.91	66.0	3.32	82.5	3.73	102.0	4.14	122.5	4.55	144.6	4.96	169.2	5.37	196.5	5.78	220.5
2.10	35.6	2.51	51.0	2.92	66.4	3.33	82.9	3.74	102.5	4.15	123.0	4.56	145.2	4.97	169.8	5.38	197.0	5.79	221.3
2.11	36.0	2.52	51.4	2.93	66.7	3.34	83.4	3.75	103.0	4.16	123.5	4.57	145.8	4.98	170.4	5.39	197.5	5.80	222.0
2.12	36.4	2.53	51.7	2.94	67.1	3.35	83.8	3.76	103.5	4.17	124.0	4.58	146.4	4.99	171.0	5.40	198.0	5.81	222.8
2.13	36.7	2.54	52.1	2.95	67.5	3.36	84.3	3.77	104.0	4.18	124.5	4.59	147.0	5.00	171.6	5.41	198.5	5.82	223.5
2.14	37.1	2.55	52.5	2.96	67.9	3.37	84.7	3.78	104.5	4.19	125.0	4.60	147.6	5.01	172.2	5.42	199.0	5.83	224.3
2.15	37.5	2.56	52.9	2.97	68.2	3.38	85.1	3.79	105.0	4.20	125.5	4.61	148.2	5.02	172.8	5.43	199.5	5.84	225.0
2.16	37.9	2.57	53.2	2.98	68.6	3.39	85.6	3.80	105.5	4.21	126.0	4.62	148.8	5.03	173.4	5.44	200.0	5.85	225.8
2.17	38.2	2.58	53.6	2.99	69.0	3.40	86.0	3.81	106.0	4.22	126.5	4.63	149.4	5.04	174.0	5.45	200.5	5.86	226.5
2.18	38.6	2.59	54.0	3.00	69.4	3.41	86.5	3.82	106.5	4.23	127.0	4.64	150.0	5.05	174.6	5.46	201.0	5.87	227.3
2.19	39.0	2.60	54.4	3.01	69.7	3.42	86.9	3.83	107.0	4.24	127.5	4.65	150.6	5.06	175.2	5.47	201.5	5.88	228.0
2.20	39.4	2.61	54.7	3.02	70.1	3.43	87.3	3.84	107.5	4.25	128.0	4.66	151.2	5.07	175.8	5.48	202.0	5.89	228.8
2.21	39.7	2.62	55.1	3.03	70.5	3.44	87.8	3.85	108.0	4.26	128.5	4.67	151.8	5.08	176.4	5.49	202.5	5.90	229.5
2.22	40.1	2.63	55.5	3.04	70.9	3.45	88.2	3.86	108.5	4.27	129.0	4.68	152.4	5.09	177.0	5.50	203.0	5.91	230.3
2.23	40.5	2.64	55.9	3.05	71.2	3.46	88.7	3.87	109.0	4.28	129.5	4.69	153.0	5.10	177.6	5.51	203.5	5.92	231.0
2.24	40.9	2.65	56.2	3.06	71.6	3.47	89.1	3.88	109.5	4.29	130.0	4.70	153.6	5.11	178.2	5.52	204.0	5.93	231.8
2.25	41.2	2.66	56.6	3.07	72.0	3.48	89.6	3.89	110.0	4.30	130.5	4.71	154.2	5.12	178.8	5.53	204.5	5.94	232.5
2.26	41.6	2.67	57.0	3.08	72.4	3.49	90.0	3.90	110.5	4.31	131.0	4.72	154.8	5.13	179.4	5.54	205.0	5.95	233.3
2.27	42.0	2.68	57.4	3.09	72.7	3.50	90.5	3.91	111.0	4.32	131.5	4.73	155.4	5.14	180.0	5.55	205.5	5.96	234.0
2.28	42.4	2.69	57.7	3.10	73.1	3.51	91.0	3.92	111.5	4.33	132.0	4.74	156.0	5.15	180.8	5.56	206.0	5.97	234.8
2.29	42.7	2.70	58.1	3.11	73.5	3.52	91.5	3.93	112.0	4.34	132.5	4.75	156.6	5.16	181.5	5.57	206.5	5.98	235.5
2.30	43.1	2.71	58.5	3.12	73.9	3.53	92.0	3.94	112.5	4.35	133.0	4.76	157.2	5.17	182.3	5.58	207.0	5.99	236.3
2.31	43.5	2.72	58.9	3.13	74.2	3.54	92.5	3.95	113.0	4.36	133.5	4.77	157.8	5.18	183.0	5.59	207.5	6.00	237.0
2.32	43.9	2.73	59.2	3.14	74.6	3.55	93.0	3.96	113.5	4.37	134.0	4.78	158.4	5.19	183.8	5.60	208.0	6.01	237.8
2.33	44.2	2.74	59.6	3.15	75.0	3.56	93.5	3.97	114.0	4.38	134.5	4.79	159.0	5.20	184.5	5.61	208.5	6.02	238.5
2.34	44.6	2.75	60.0	3.16	75.4	3.57	94.0	3.98	114.5	4.39	135.0	4.80	159.6	5.21	185.3	5.62	209.0	6.03	239.3
2.35	45.0	2.76	60.4	3.17	75.9	3.58	94.5	3.99	115.0	4.40	135.6	4.81	160.2	5.22	186.0	5.63	209.5	6.04	240.0

**Fire Resistance Rating, minutes per inches of equivalent thickness  
Direct Interpolation from table 721.3.2 of the 2007 Florida Building Code  
Stucco/Sand Finish Block Mix – 100% Limestone**

et	min	et	min	et	min	et	min	et	min	et	min	et	min	et	min	et	min	et	min	et	min
1.90	30.0	2.31	45.4	2.72	60.8	3.13	76.5	3.54	92.0	3.95	107.5	4.36	123.0	4.77	138.5	5.18	154.0	5.59	169.5	6.00	185.0
1.91	30.4	2.32	45.8	2.73	61.1	3.14	77.0	3.55	92.5	3.96	108.0	4.37	123.5	4.78	139.0	5.19	154.5	5.60	170.0	6.01	185.5
1.92	30.8	2.33	46.1	2.74	61.5	3.15	77.5	3.56	93.0	3.97	108.5	4.38	124.0	4.79	139.5	5.20	155.0	5.61	170.5	6.02	186.0
1.93	31.1	2.34	46.5	2.75	61.9	3.16	78.0	3.57	93.5	3.98	109.0	4.39	124.5	4.80	140.0	5.21	155.5	5.62	171.0	6.03	186.5
1.94	31.5	2.35	46.9	2.76	62.3	3.17	78.5	3.58	94.0	3.99	109.5	4.40	125.0	4.81	140.5	5.22	156.0	5.63	171.5	6.04	187.0
1.95	31.9	2.36	47.3	2.77	62.6	3.18	79.0	3.59	94.5	4.00	110.0	4.41	125.5	4.82	141.0	5.23	156.5	5.64	172.0	6.05	187.5
1.96	32.3	2.37	47.6	2.78	63.0	3.19	79.5	3.60	95.0	4.01	110.5	4.42	126.0	4.83	141.5	5.24	157.0	5.65	172.5	6.06	188.0
1.97	32.6	2.38	48.0	2.79	63.4	3.20	80.0	3.61	95.5	4.02	111.0	4.43	126.5	4.84	142.0	5.25	157.5	5.66	173.0	6.07	188.5
1.98	33.0	2.39	48.4	2.80	63.7	3.21	80.5	3.62	96.0	4.03	111.5	4.44	127.0	4.85	142.5	5.26	158.0	5.67	173.5	6.08	189.0
1.99	33.4	2.40	48.8	2.81	64.1	3.22	81.0	3.63	96.5	4.04	112.0	4.45	127.5	4.86	143.0	5.27	158.5	5.68	174.0	6.09	189.5
2.00	33.8	2.41	49.1	2.82	64.5	3.23	81.5	3.64	97.0	4.05	112.5	4.46	128.0	4.87	143.5	5.28	159.0	5.69	174.5	6.10	190.0
2.01	34.1	2.42	49.5	2.83	64.9	3.24	82.0	3.65	97.5	4.06	113.0	4.47	128.5	4.88	144.0	5.29	159.5	5.70	175.0	6.11	190.5
2.02	34.5	2.43	49.9	2.84	65.2	3.25	82.5	3.66	98.0	4.07	113.5	4.48	129.0	4.89	144.5	5.30	160.0	5.71	175.5	6.12	191.0
2.03	34.9	2.44	50.3	2.85	65.6	3.26	83.0	3.67	98.5	4.08	114.0	4.49	129.5	4.90	145.0	5.31	160.5	5.72	176.0	6.13	191.5
2.04	35.3	2.45	50.6	2.86	66.0	3.27	83.5	3.68	99.0	4.09	114.5	4.50	130.0	4.91	145.5	5.32	161.0	5.73	176.5	6.14	192.0
2.05	35.6	2.46	51.0	2.87	66.4	3.28	84.0	3.69	99.5	4.10	115.0	4.51	130.5	4.92	146.0	5.33	161.5	5.74	177.0	6.15	192.5
2.06	36.0	2.47	51.4	2.88	66.7	3.29	84.5	3.70	100.0	4.11	115.5	4.52	131.0	4.93	146.5	5.34	162.0	5.75	177.5	6.16	193.0
2.07	36.4	2.48	51.7	2.89	67.1	3.30	85.0	3.71	100.5	4.12	116.0	4.53	131.5	4.94	147.0	5.35	162.5	5.76	178.0	6.17	193.5
2.08	36.7	2.49	52.1	2.90	67.5	3.31	85.5	3.72	101.0	4.13	116.5	4.54	132.0	4.95	147.5	5.36	163.0	5.77	178.5	6.18	194.0
2.09	37.1	2.50	52.5	2.91	67.9	3.32	86.0	3.73	101.5	4.14	117.0	4.55	132.5	4.96	148.0	5.37	163.5	5.78	179.0	6.19	194.5
2.10	37.5	2.51	52.9	2.92	68.2	3.33	86.5	3.74	102.0	4.15	117.5	4.56	133.0	4.97	148.5	5.38	164.0	5.79	179.5	6.20	195.0
2.11	37.9	2.52	53.2	2.93	68.6	3.34	87.0	3.75	102.5	4.16	118.0	4.57	133.5	4.98	149.0	5.39	164.5	5.80	180.0	6.21	195.5
2.12	38.2	2.53	53.6	2.94	69.0	3.35	87.5	3.76	103.0	4.17	118.5	4.58	134.0	4.99	149.5	5.40	165.0	5.81	180.5	6.22	196.0
2.13	38.6	2.54	54.0	2.95	69.4	3.36	88.0	3.77	103.5	4.18	119.0	4.59	134.5	5.00	150.0	5.41	165.5	5.82	181.0	6.23	196.5
2.14	39.0	2.55	54.4	2.96	69.7	3.37	88.5	3.78	104.0	4.19	119.5	4.60	135.0	5.01	150.5	5.42	166.0	5.83	181.5	6.24	197.0
2.15	39.4	2.56	54.7	2.97	70.1	3.38	89.0	3.79	104.5	4.20	120.0	4.61	135.5	5.02	151.0	5.43	166.5	5.84	182.0	6.25	197.5
2.16	39.7	2.57	55.1	2.98	70.5	3.39	89.5	3.80	105.0	4.21	120.5	4.62	136.0	5.03	151.5	5.44	167.0	5.85	182.5	6.26	198.0
2.17	40.1	2.58	55.5	2.99	70.9	3.40	90.0	3.81	105.5	4.22	121.0	4.63	136.5	5.04	152.0	5.45	167.5	5.86	183.0	6.27	198.5
2.18	40.5	2.59	55.9	3.00	71.2	3.41	90.5	3.82	106.0	4.23	121.5	4.64	137.0	5.05	152.5	5.46	168.0	5.87	183.5	6.28	199.0
2.19	40.9	2.60	56.2	3.01	71.6	3.42	91.0	3.83	106.5	4.24	122.0	4.65	137.5	5.06	153.0	5.47	168.5	5.88	184.0	6.29	199.5
2.20	41.2	2.61	56.6	3.02	72.0	3.43	91.5	3.84	107.0	4.25	122.5	4.66	138.0	5.07	153.5	5.48	169.0	5.89	184.5	6.30	200.0
2.21	41.6	2.62	57.0	3.03	72.4	3.44	92.0	3.85	107.5	4.26	123.0	4.67	138.5	5.08	154.0	5.49	169.5	5.90	185.0	6.31	200.5
2.22	42.0	2.63	57.4	3.04	72.7	3.45	92.5	3.86	108.0	4.27	123.5	4.68	139.0	5.09	154.5	5.50	170.0	5.91	185.5	6.32	201.0
2.23	42.4	2.64	57.7	3.05	73.1	3.46	93.0	3.87	108.5	4.28	124.0	4.69	139.5	5.10	155.0	5.51	170.5	5.92	186.0	6.33	201.5
2.24	42.7	2.65	58.1	3.06	73.5	3.47	93.5	3.88	109.0	4.29	124.5	4.70	140.0	5.11	155.5	5.52	171.0	5.93	186.5	6.34	202.0
2.25	43.1	2.66	58.5	3.07	73.9	3.48	94.0	3.89	109.5	4.30	125.0	4.71	140.5	5.12	156.0	5.53	171.5	5.94	187.0	6.35	202.5
2.26	43.5	2.67	58.9	3.08	74.2	3.49	94.5	3.90	110.0	4.31	125.5	4.72	141.0	5.13	156.5	5.54	172.0	5.95	187.5	6.36	203.0
2.27	43.9	2.68	59.2	3.09	74.6	3.50	95.0	3.91	110.5	4.32	126.0	4.73	141.5	5.14	157.0	5.55	172.5	5.96	188.0	6.37	203.5
2.28	44.2	2.69	59.6	3.10	75.0	3.51	95.5	3.92	111.0	4.33	126.5	4.74	142.0	5.15	157.5	5.56	173.0	5.97	188.5	6.38	204.0
2.29	44.6	2.70	60.0	3.11	75.5	3.52	96.0	3.93	111.5	4.34	127.0	4.75	142.5	5.16	158.0	5.57	173.5	5.98	189.0	6.39	204.5
2.30	45.0	2.71	60.4	3.12	76.0	3.53	96.5	3.94	112.0	4.35	127.5	4.76	143.0	5.17	158.5	5.58	174.0	5.99	189.5	6.40	205.0